

SPECIFICATION	VALUE
POWER (Kw)	2.2
VOLTAGE (VAC)	110
RATED CURRENT (A)	16
MAXIMUM SPEED (RPM)	24000
FREQUENCY (Hz)	400
NUT MODEL	ER20
COLLET (mm)	Ø6
COOLING	WATER COOLED
MATERIAL	STAINLESS STEEL
LUBRICATION	GREASE
WEIGHT (Kg) [lb]	5.25 [11.57]

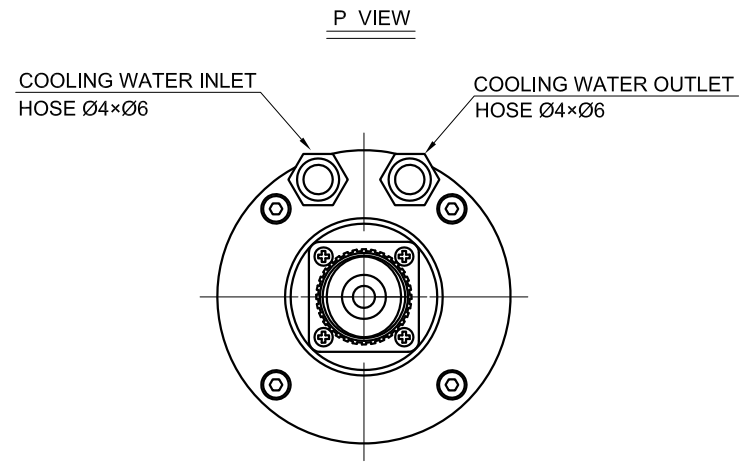

STEPPERONLINE®

mm	APVD	10.26.2022
UNIT	CHKD	
2:1	DRN	
SCALE	SIGNATURE	DATE

SPINDLE MOTOR

GDZ80-2.2A