

SPECIFICATION	VALUE
NO. of PHASES	3
NO. of POLES	4
RATED VOLTAGE(V)	24
RATED CURRENT(A)	14±10%
RATED POWER(W)	220
RATED SPEED(RPM)	3500±10%
RATED TORQUE(mN.m)	600
HALL LEAD STYLE	UL 1007 AWG26
PHASE LEAD STYLE	UL 1007 AWG16
SENSOR	HALL SENSOR
INSULATION CLASS	CLASS B
INSULATION RESISTANCE	100MΩ MIN @ 500VDC
DIELECTRIC STRENGTH TEST	500VAC for 1 MINUTE
BEARING TYPE	NMB BALL BEARING, C3

HALL LEAD: UL 1007 26AWG

PHASE LEAD: UL 1007 16AWG

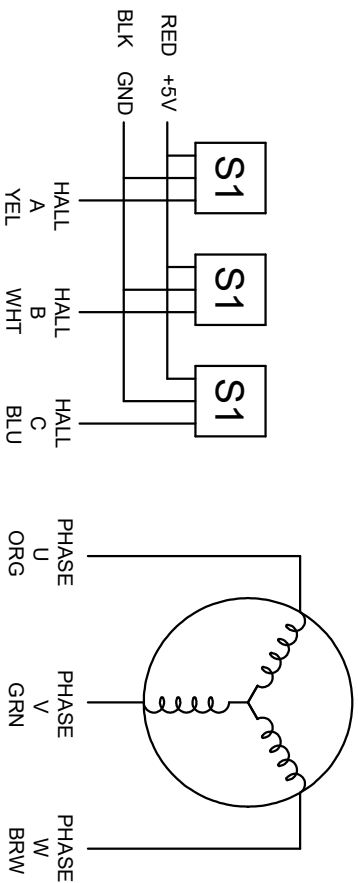

**STEPPERONLINE**  
 MOTOR & ACCESSORIES

SCALE 1.5:1

APVD			
CHKD			
DRN			
SIGNATURE			
DATE			

**BRUSHLESS DC MOTOR**

57BLR90-24-01