

SPECIFICATION	VALUE
NO. of PHASES	3
NO. of POLES	4
RATED VOLTAGE(V)	24
RATED CURRENT(A)	9±10%
RATED POWER(W)	134
RATED SPEED(RPM)	3500±10%
RATED TORQUE(mN.m)	370
HALL LEAD STYLE	UL 1007 AWG26
PHASE LEAD STYLE	UL 1007 AWG18
SENSOR	HALL SENSOR
INSULATION CLASS	CLASS B
INSULATION RESISTANCE	100MΩ MIN @ 500VDC
DIELECTRIC STRENGTH TEST	500VAC for 1 MINUTE
BEARING TYPE	NMB BALL BEARING, C3

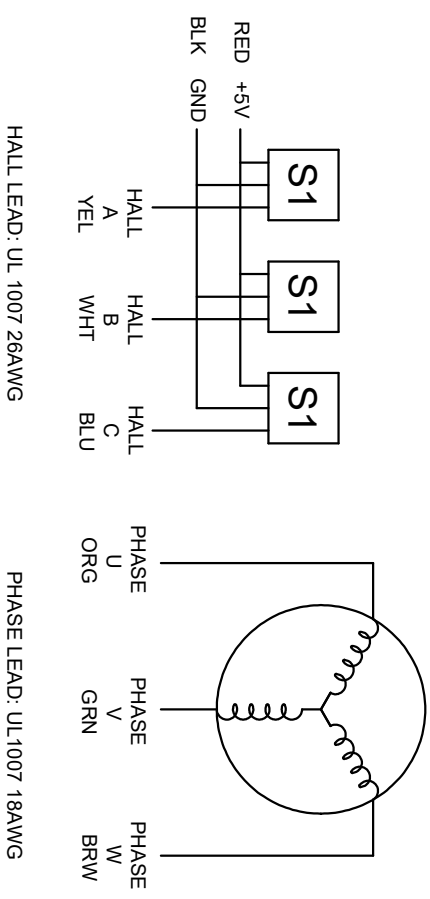

		APVD		<h1>BRUSHLESS DC MOTOR</h1>
		CHKD		
SCALE		DRN		<h2>57BLR70-24-01</h2>
1.5:1		SIGNATURE		
		DATE		