

# STEPPERONLINE®

## User Manual

# DM860T(V3.0)

## 2-Phase Digital Stepper Drive

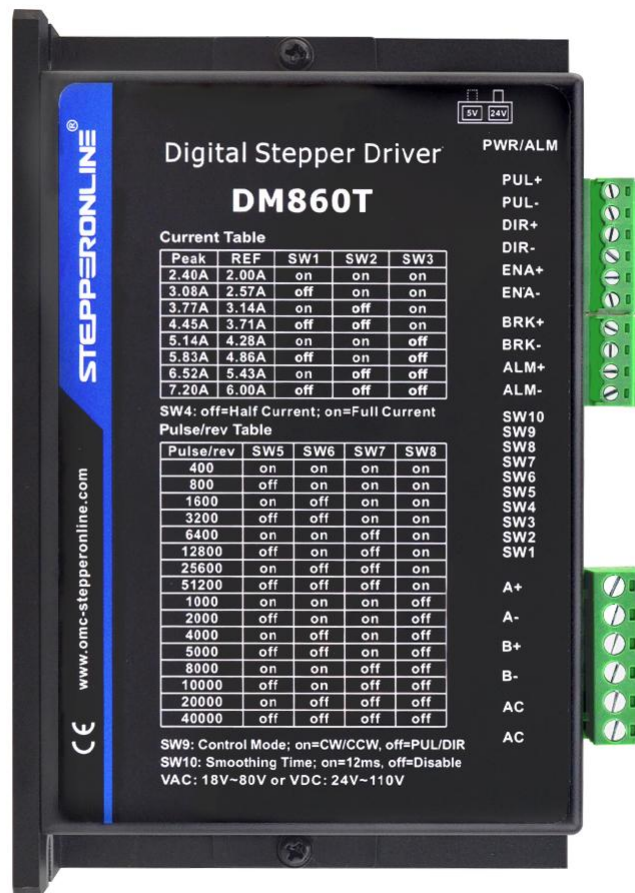

Revision 3.0

### Record of Revisions

Revision	Date	Description of Release
1.0	Dec, 2016	Initial Release
3.0	Oct, 2020	Add 5/24V logical voltage selector, alarm & Brake outputs CW&CCW control

---

# Table of Contents

1. Features .....	1
2. Specifications .....	1
2.1 Electrical Specifications .....	1
2.2 Environment .....	1
2.3 Mechanical Specifications .....	2
2.4 Elimination of Heat .....	2
3. Connection Pin Assignments and LED Indication .....	2
3.1 P1 - Control Connector .....	3
3.2 P2 - Fault Output Connector .....	3
3.3 P3 - Motor and Power Supply Connector .....	3
3.4 LED Light Indication .....	4
4. Control Signal and Output Signal .....	4
4.1 Control Signal Connection .....	4
4.2 Fault and Brake Output Connection .....	4
5. Motor Connection .....	5
6. Power Supply Selection .....	5
6.1 Power Supply Sharing .....	5
6.2 Selecting Supply Voltage .....	5
7. DIP Switch Configurations .....	6
7.1 Microstep Resolution Configurations .....	6
7.2 Output Current Configurations .....	7
7.2.1 Dynamic Current Configurations .....	7
7.2.2 Idle Current Configuration .....	7
7.3 Control Mode Configurations .....	7
7.4 Smoothing Time Configuration .....	7
7.5 Automatic Motor Matching & Self Configuration .....	7
8. Wiring Notes .....	8
9. Typical Connection .....	8
10. Sequence Chart of Control Signals .....	9
11. Protection Functions .....	9
12. Troubleshooting .....	10

## 1. Features

- Step & direction (PUL/DIR) or CW/CCW (double pulse) control set by SW9
- Input voltage 18-80VAC or 24-110VDC (recommended 20-70VAC or 30-100VDC)
- 200 KHz max pulse input frequency
- 8 output current settings of 2.4-7.2A via DIP Switches SW1-SW3
- Idle current reduction to 50% or 90% selection via SW4
- 16 microstep resolutions of 400-51,200 via DIP switches SW5-SW8
- Control command smoothing for reducing motor vibration set by SW10
- Auto-tuning to match wide-range NEMA 23, 24, 34 and 42 stepper motors
- Anti-Resonance for optimal torque, extra smooth motion, low motor heating and noise
- Optically isolated inputs with 5V or 24V
- Fault and Brake outputs
- Over-voltage and over-current protections

## 2. Specifications

### 2.1 Electrical Specifications

Parameters	DM860T(V3.0)			
	Min	Typical	Max	Unit
Output Current	2.4	-	7.2	A
Supply Voltage	18	20 - 70	80	VAC
	24	30 - 100	110	VDC
Logic signal current	7	10	16	mA
Pulse input frequency	0	-	200	kHz
Minimal Pulse Width	2.5	-	-	μS
Minimal Direction Setup	5.0	-	-	μS
Isolation resistance	500			MΩ

### 2.2 Environment

Cooling	Natural Cooling or Forced cooling	
Operating Environment	Environment	Avoid dust, oil fog and corrosive gases
	Humidity	40%RH — 90%RH
	Operating Temperature	0°C — 40°C (32°F - 109°F)
	Vibration	10-50Hz / 0.15mm
Storage Temperature	-20°C — 65°C (-4°F - 149°F)	
Weight	Approx. 510g (1.13 lbs)	

**2.3 Mechanical Specifications**

(unit: mm [1inch=25.4mm])

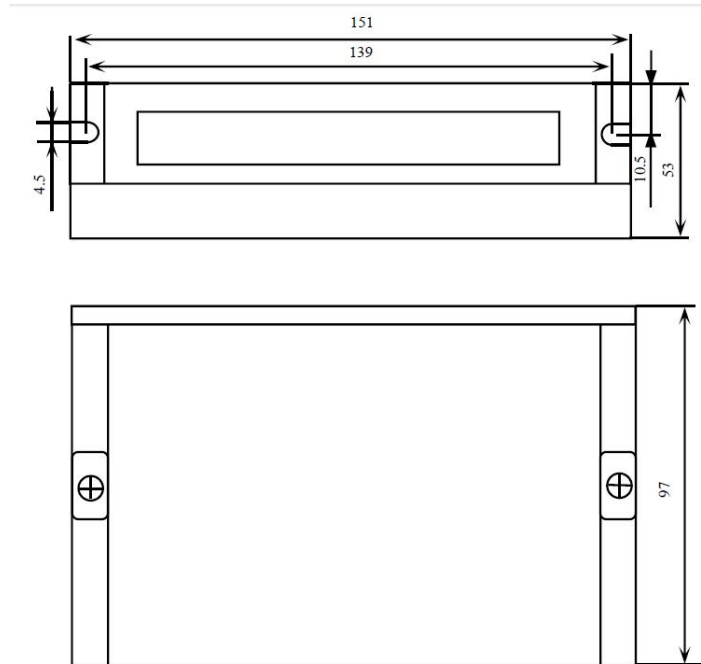

**Figure 1** Mechanical specifications

- Side mounting recommended for better heat dissipation

**2.4 Elimination of Heat**

- DM860T(V3.0) reliable working temperature should be < 40°C (109°F)
- It is recommended to use automatic idle-current mode to reduce motor heating. That means set the SW4 pin of DIP switch at “OFF” position.
- It is recommended to mount the drive vertically to maximize heat sink area. Use forced cooling method to cool if necessary.

**3. Connection Pin Assignments and LED Indication**

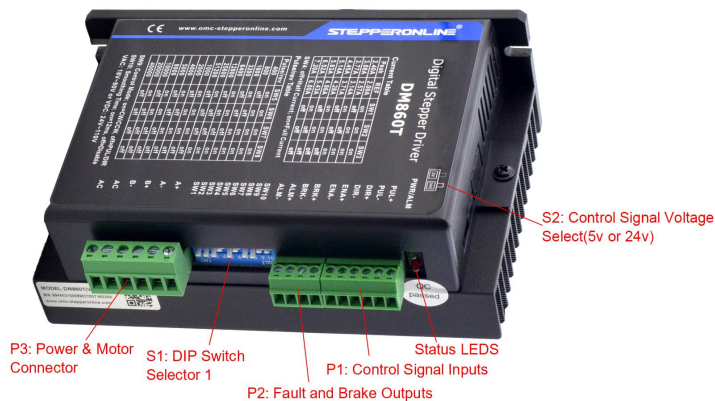

**Figure 2** Connectors, DIP switches, and LED locations

The DM860T(V3.0) has three connector blocks P1&P2&P3 (see above picture). P1 is for control signals connections, and P2 is for output signals connections, P3 is for power and motor connections. The following tables are brief descriptions of the three connectors. More detailed descriptions of the pins and related issues are as below.

### 3.1 P1 - Control Connector

PIN	Details
PUL+ (CW+)	<u>Pulse and Direction Connection:</u> <b>(1)</b> Optically isolated, high level 4.5-5V or 24V, low voltage 0-0.5V <b>(2)</b> Maximum 200 KHz input frequency <b>(3)</b> The width of PUL signal is at least 2.5µs, duty cycle is recommended 50% <b>(4)</b> Single pulse (step & direction) or double pulse (CW/CCW) is set by DIP Switch SW9 <b>(5)</b> DIR signal requires advance PUL signal minimum 5 µs in single pulse mode <b>(6)</b> The factory setting of control signal voltage is 24V, <b>must need</b> to set S2 (figure 2) if it is 5V
PUL- (CW-)	
DIR+ (CCW+)	
DIR- (CCW-)	
ENA+	<u>Enable Connection:</u> (default no connection) <b>(1)</b> Optically isolated, differential. <b>(2)</b> Disable the drive by 4.5- 24V input connection; enable the drive by 0-0.5V connection <b>(3)</b> ENA signal requires advance DIR signal minimum 5µs in single pulse mode <b>(4)</b> Enable time to be at least 200ms
ENA-	

**Notes:**

- (1) Shield cables are required for P1;
- (2) Don't tie P1/P2 cables and P3 cables together.

### 3.2 P2 - Fault Output Connector

Pin	Details
BRK+	<b>(1)</b> Maximum 30V/100mA output <b>(4)</b> Brake connection refer to <a href="#">chapter 4.2</a>
BRK-	
ALM+	<b>(1)</b> Maximum 30V/100mA output <b>(2)</b> Sinking or sourcing <b>(3)</b> The resistance between ALM+ and ALM- is low impedance as default, and will change to high when the drive goes into error protection. <b>(4)</b> Fault connection refer to <a href="#">chapter 4.2</a>
ALM-	

### 3.3 P3 - Motor and Power Supply Connector

Pin Function	Details
A+, A-	Motor Phase A connections. Connect motor A+ wire to A+ Pin; motor A- wire to A-
B+, B-	Motor Phase B connections. Connect motor B+ wire to B+ Pin; motor B- wire to B-
AC	Power supply input 18-80VAC or 24-110 VDC(recommended 20-70VAC or 30-100VDC);
AC	No polarity



**Warning:** Don't plug or unplug the P1&P2&P3 terminal block to avoid drive damage or injury when DM860T(V3.0) is powered on.

**3.4 LED Light Indication**

There are two LED lights for DM860T(V3.0). The GREEN one is the power indicator which will be always on generally. The RED one is a protection indicator which will flash 1-2 times in a 3-second period, when protection enabled for a DM860T(V3.0). Different number of flashes indicates different protection type (read section 11 for detail).

**4. Control Signal and Output Signal**

**4.1 Control Signal Connection**

The DM860T(V3.0) can accept can accept differential or single-ended control signals (pulse, direction, and enable) in open-collector or PNP connection through the P1 connector (figure 2). It is recommend to add an EMI line filter between the power supply and the drive to increase noise immunity for the drive in interference environments.

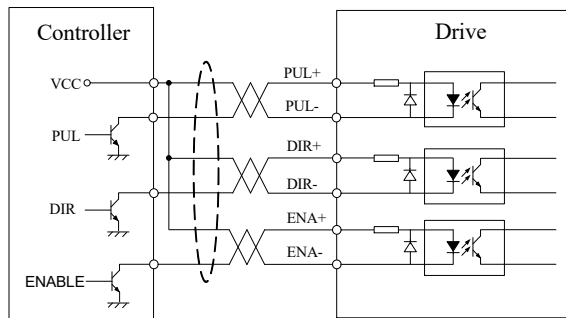

**Figure 3:** Connections to open-collector signal (common-anode)

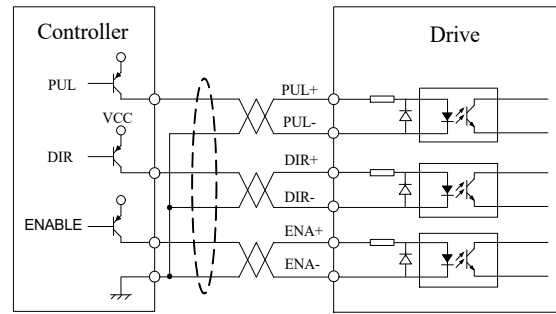

**Figure 4:** Connections to PNP signal (common-cathode)

**Notes:**

- (1) ENA signal is no-connected as default;
- (2) Control signal amplitude is 24 V as default. If it is 12 V, please set the S2 (Figure 2) selector switch to 5 V first, then connect 1KΩ resistor; If it is 5V, please set the S2 to 5V.

**4.2 Fault and Brake Output Connection**

• *Fault Output*

When over voltage or over current protection happens, DM860T(V3.0) red status LED light will blink and the impedance state between ALM+ and ALM- will change (from low to high or high to low depending on configuration) and can thus be detected. Fault output connection is optional, and it can be connected either in sinking or sourcing.

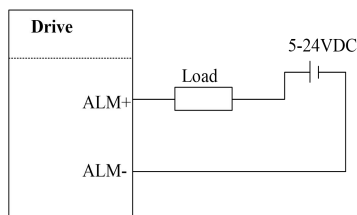

**Figure 5:** Sinking output

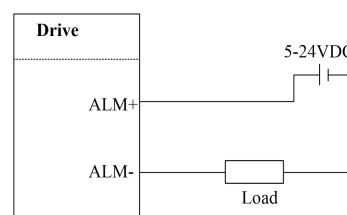

**Figure 6:** Sourcing output

• *Brake Control*

It is recommended to connect a fly-wheel diode in parallel to a 24VDC relay and brake coil connection. Refer to the following figure for brake connection.

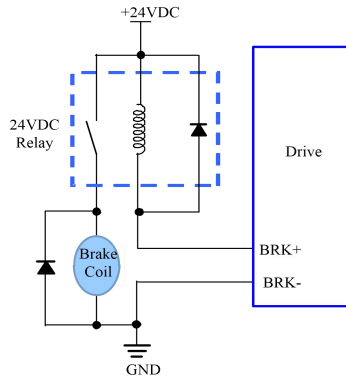
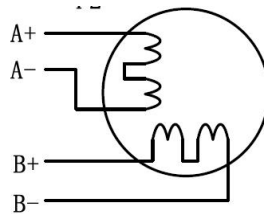

**Figure 7:** Brake output

## 5. Motor Connection

The DM860T(V3.0) can drive 2-phase and 4-phase bipolar hybrid stepper motors with 4, 6, or 8 wires.

The 4 lead motors are the least flexible and easy to connect. And the Speed – torque of motor depends on winding inductance. The output current from drive that is multiply the specified phase current by 1.4 to determine the peak output current.



**Figure 8:** 4-lead Motor Connections

## 6. Power Supply Selection

The DM860T(V3.0) can power medium and large size stepping motors (frame size from NEMA 23 to 42). To get good driving performances, it is important to select supply voltage and output current properly. Generally speaking, supply voltage determines the high speed performance of the motor, while output current determines the output torque of the driven motor (particularly at lower speed). Higher supply voltage will allow higher motor speed to be achieved, at the price of more noise and heating. If the motion speed requirement is low, it's better to use lower supply voltage to decrease noise, heating and improve reliability.

### 6.1 Power Supply Sharing

Multiple DM860T(V3.0) drives can share one power supply to reduce cost, if that power supply has enough power capacity. To avoid cross interference, connect each stepper drive directly to the shared power supply separately. To avoid cross interference, DO NOT daisy-chain connect the power supply input pins of the Drivers. Instead connect them to power supply separately.

### 6.2 Selecting Supply Voltage

The DM860T(V3.0) is designed to operate within 18 - 80VAC or 24-110VDC input. When selecting a power supply, besides voltage from the power supply power line voltage fluctuation and back EMF voltage generated during motor deceleration needs also to be taken into account. Please make sure leaving enough room for power line voltage

fluctuation and back-EMF voltage charge back.

Higher supply voltage can increase motor torque at higher speeds, thus helpful for avoiding losing steps. However, higher voltage may cause bigger motor vibration at lower speed, and it may also cause over-voltage protection or even drive damage. Therefore, it is suggested to choose only sufficiently high supply voltage for intended applications.

## 7. DIP Switch Configurations

The DM860T(V3.0) has one 10-bit DIP switch and one 1-bit selector. The first 10-bit is used to configure settings of micro step resolution, output current, motor standstill current, pulse type and smoothing time as shown below.

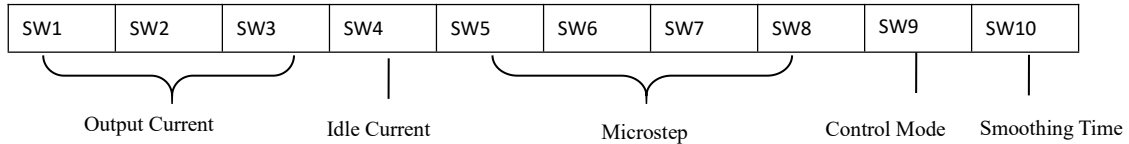

The second 1-bit selector is located on the top (S2 in figure 2), used to configure the voltage of control signals. For the safety of optically coupled, the factory setting is 24V, which no need to connect 2K resistors like the old drives, making it easier to use. When the voltage of the control signal is 5V, the S2 must be set to 5V, otherwise, [the motor won't work](#).

### 7.1 Microstep Resolution Configurations

Microstep resolution is set by SW5, 6, 7, 8 of the DIP switches as shown in the following table.

Microstep	Steps/rev.(for 1.8°motor)	SW5	SW6	SW7	SW8
2	400	ON	ON	ON	ON
4	800	OFF	ON	ON	ON
8	1600	ON	OFF	ON	ON
16	3200	OFF	OFF	ON	ON
32	6400	ON	ON	OFF	ON
64	12800	OFF	ON	OFF	ON
128	25600	ON	OFF	OFF	ON
256	51200	OFF	OFF	OFF	ON
5	1000	ON	ON	ON	OFF
10	2000	OFF	ON	ON	OFF
20	4000	ON	OFF	ON	OFF
25	5000	OFF	OFF	ON	OFF
40	8000	ON	ON	OFF	OFF
50	10000	OFF	ON	OFF	OFF
100	20000	ON	OFF	OFF	OFF
200	40000	OFF	OFF	OFF	OFF



**7.2 Output Current Configurations**

For a given motor, higher drive current will make the motor to output more torque, but at the same time causes more heating in the motor and drive. Therefore, output current is generally set to be such that the motor will not overheat for long time operation. Since parallel and serial connections of motor coils will significantly change resulting inductance and resistance, it is therefore important to set drive output current depending on motor phase current, motor leads and connection methods. Phase current rating supplied by motor manufacturer is important in selecting drive current, however the selection also depends on leads and connections.

The first three bits (SW1, 2, 3) of the DIP switch are used to set the dynamic current. Select a setting closest to your motor’s required current.

**7.2.1 Dynamic Current Configurations**

Peak Current	RMS Current	SW1	SW2	SW3
2.40A	2.00A	ON	ON	ON
3.08A	2.57A	OFF	ON	ON
3.77A	3.14A	ON	OFF	ON
4.45A	3.71A	OFF	OFF	ON
5.14A	4.28A	ON	ON	OFF
5.83A	4.86A	OFF	ON	OFF
6.52A	5.43A	ON	OFF	OFF
7.20A	6.00A	OFF	OFF	OFF

**Notes:** Due to motor inductance, the actual current in the coil may be smaller than the dynamic current setting, particularly under high speed condition.

**7.2.2 Idle Current Configuration**

SW4 is used to set motor idle current percentage. At OFF position it means the standstill current is set to be 50% of the selected output current. At ON position it means standstill current is set to be 90%.

The current automatically reduced to 50% of the selected dynamic current 0.4 second after the last pulse.

**7.3 Control Mode Configurations**

DIP switch SW9 is used to configure the control mode. Factory setting is single pulse (step & direction, or pulse & direction) control. Setting to ON to change the control model to double pulse (CW/CCW) control type.

**7.4 Smoothing Time Configuration**

DM860T(V3.0) has an advanced feature called control command smoothing to make the input pulse from pulse generator (controller, PLC, etc.) S-curve acceleration, to improve motion smoothness and high-speed start frequency in many circumstances. This is achieved through adding filtering time which is configured SW10. Setting to ON to activate the feature with 12ms acceleration time.

In short, setting SW10 to OFF allows the motor to respond faster at high subdivisions. Setting SW10 to ON allows the motor to run more smoothly at low subdivisions.

**7.5 Automatic Motor Matching & Self Configuration**

When powered on a DM860T(V3.0) will automatically configure itself with the best settings to match the driven stepper motor for optimal performance. No action is needed.

## 8. Wiring Notes

- In order to improve anti-interference performance of the drive, it is recommended to use twisted pair shield cable.
- To prevent noise incurred in PUL/DIR signal, pulse/direction signal wires and motor wires should not be tied up together. It is better to separate them by at least 10 cm, otherwise the disturbing signals generated by motor will easily disturb pulse direction signals, causing motor position error, system instability and other failures.
- If only one power supply serves multiple DM860T(V3.0) drives, separately connecting the drives to the power supply is recommended instead of daisy-chaining.
- It is prohibited to pull and plug connector P2 while the drive is powered ON, because there is high current flowing through motor coils (even when motor is at standstill). Pulling or plugging connector P2 with power on will cause extremely high back-EMF voltage surge, which may damage the drive.

## 9. Typical Connection

A complete stepping system should include stepping motor, stepping drive, power supply and controller (pulse generator). A typical connection is shown as below.

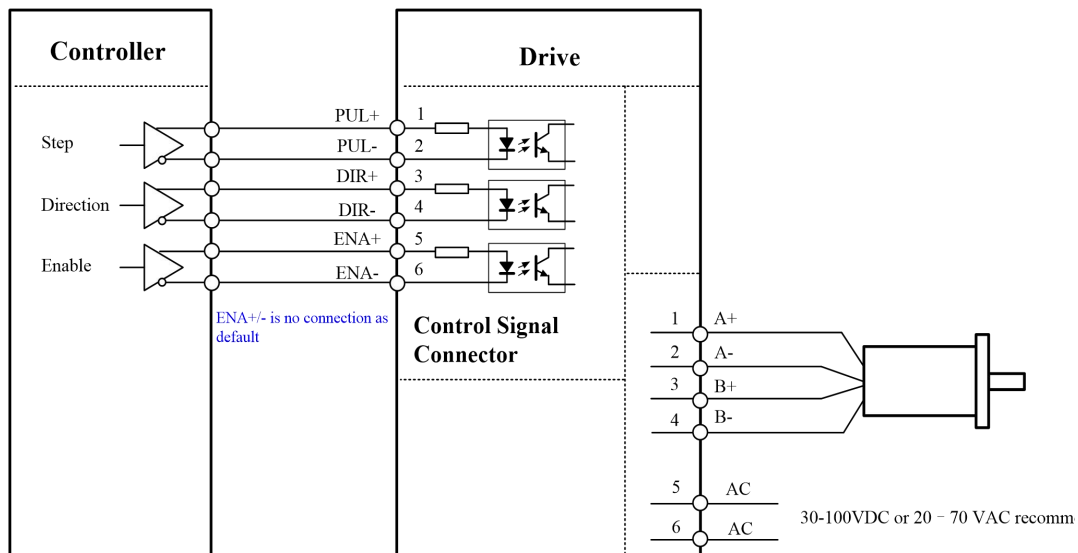

**Figure 9:** Typical connection

## 10. Sequence Chart of Control Signals

In order to avoid some fault operations and deviations, PUL, DIR and ENA should abide by some rules, shown as following diagram:

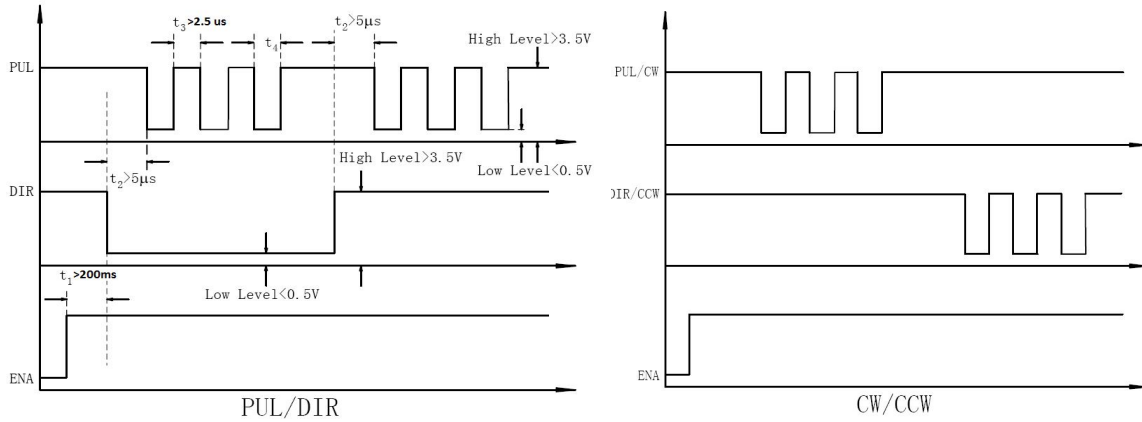

**Figure 10:** Sequence chart of control signals

**Remark:**

- a) t1: ENA must be ahead of DIR by at least 200ms. Usually, ENA+ and ENA- are NC (not connected). See “Connector P1 Configurations” for more information.
- b) t2: DIR must be ahead of PUL effective edge by 5 μs to ensure correct direction;
- c) t3: Pulse width not less than 2.5μs;
- d) t4: Low level width not less than 2.5μs;
- e) Duty cycle of Pulse signal is recommend 50%.

## 11. Protection Functions

To improve reliability, the drive incorporates some built-in protections features.

Priority	Time(s) of Blink	Sequence wave of red LED	Description
1st	1		Over-current protection activated when peak current exceeds the limit.
2nd	2		Over-voltage protection activated when drive working voltage is greater than 160VDC
3rd	3		Reserved.

When above protections are active, the motor shaft will be free or the red LED blinks. Reset the drive by repowering it to make it function properly after removing above problems.

## 12. Troubleshooting

In the event that your drive doesn't operate properly, the first step is to identify whether the problem is electrical or mechanical in nature. The next step is to isolate the system component that is causing the problem. As part of this process you may have to disconnect the individual components that make up your system and verify that they operate independently. It is important to document each step in the troubleshooting process. You may need this documentation to refer back to at a later date, and these details will greatly assist our Technical Support staff in determining the problem should you need assistance.

Many of the problems that affect motion control systems can be traced to electrical noise, controller software errors, or mistake in wiring.

### Problem Symptoms and Possible Causes

Symptoms	Possible Problems
<b>Motor is not rotating</b>	No power
	Microstep resolution setting is wrong
	DIP switch current setting is wrong
	Fault condition exists
	The drive is disabled
<b>Motor rotates in the wrong direction</b>	Motor phases may be connected in reverse
<b>The drive in fault</b>	DIP switch current setting is wrong
	Something wrong with motor coil
<b>Erratic motor motion</b>	Control signal is too weak
	Control signal is interfered
	Wrong motor connection
	Something wrong with motor coil
	Current setting is too small, losing steps
<b>Motor stalls during acceleration</b>	Current setting is too small
	Motor is undersized for the application
	Acceleration is set too high
	Power supply voltage too low
<b>Excessive motor and drive heating</b>	Inadequate heat sinking / cooling
	Automatic current reduction function not being utilized
	Current is set too high