

SPEED - TORQUE CURVE

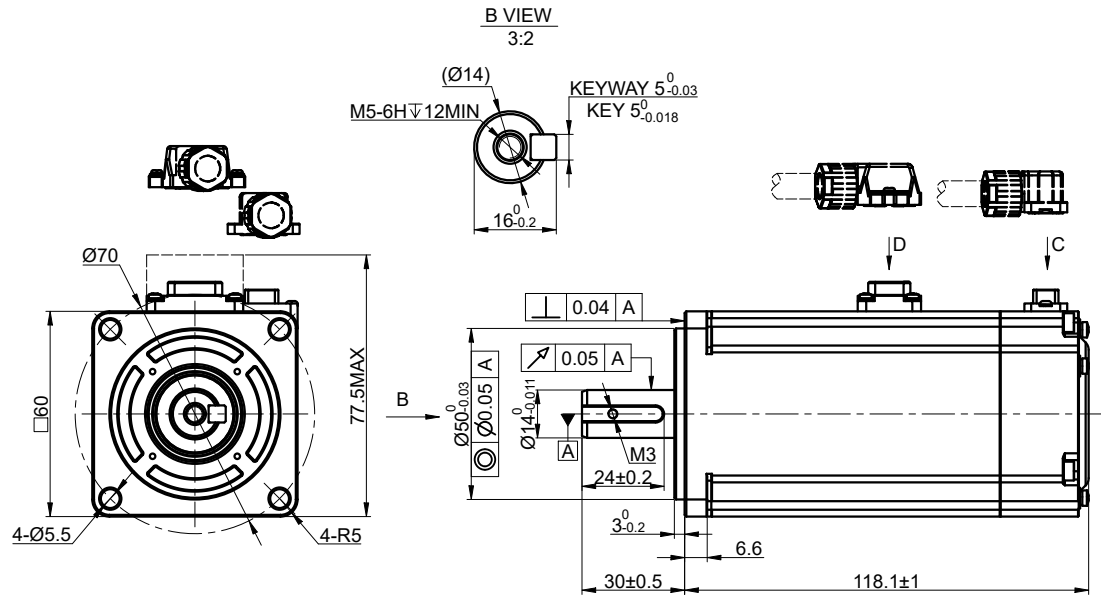
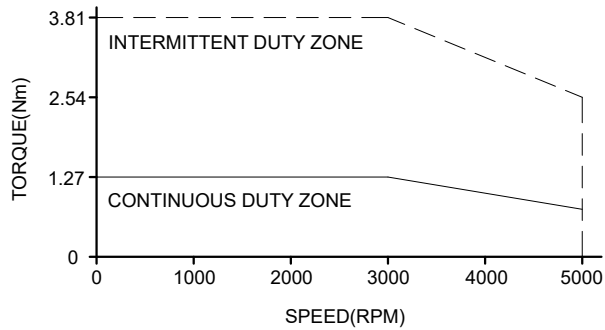

SPECIFICATION	VALUE
RATED VOLTAGE(VAC)	220
RATED POWER(W)	400
RATED TORQUE(Nm)	1.27
PEAK TORQUE(Nm)	3.81
RATED SPEED(RPM)	3000
PEAK SPEED(RPM)	5000
RATED CURRENT(Amp)	2.1
PEAK CURRENT(Amp)	6.5
TORQUE CONST(Nm/Amp)	0.645
BACK EMF CONST(V/KRPM)	39
RESISTANCE(Ω)	5.7
INDUCTANCE(mH)	12
INERTIA(Kg·m ² ·10 ⁻⁴)	0.58
POLES	10
ENCODER TYPE	23bit magnetic
IP RATING	IP67
WEIGHT(KG)	1.55

WIRING DETAILS OF POWER CABLE CONNECTOR							
	PIN No.	1	2	3	4	A	B
	DESCRIPTION	U	V	W	PE	0V	24V
	COLOR	BLK	WHT	RED	YEL/GRE	BLU	BLU

WIRING DETAILS OF ENCODER CABLE CONNECTOR								
	PIN No.	1	2	3	4	5	6	7
	DESCRIPTION	PE	5V	0V	SD+	SD-	BAT+	BAT-
	COLOR	SHIELD	RED	BLK	BLU	YEL	BRN	WHT

THE PART NUMBER OF CABLE FOR T7M60-400H2B1-M23 MOTOR		
POWER CABLE	CMST1M5-2	AWG 21
ENCODER CABLE	CEST1M5-2	AWG 25



	APVD	LDJ	4.7.2024
	CHKD		
2:1	DRN	YSX	4.7.2024
SCALE	SIGNATURE		DATE

AC SERVO MOTOR

T7M60-400H2B1-M23