

REV.	REVISION RECORD	BY	DATE
0	ORIGIN	HW	2.1.2024

CUSTOMER'S MODEL: NO MODEL
 END COVER COLOR: BLACK

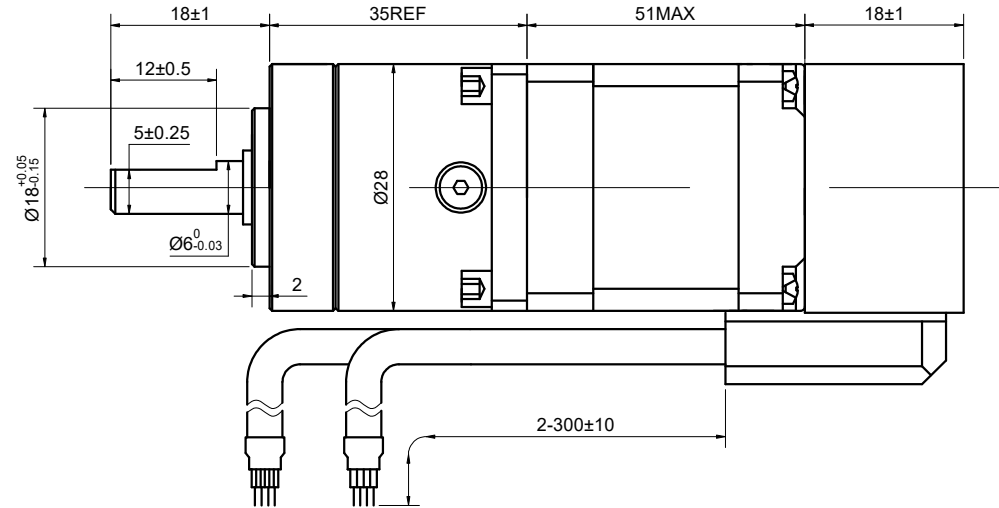
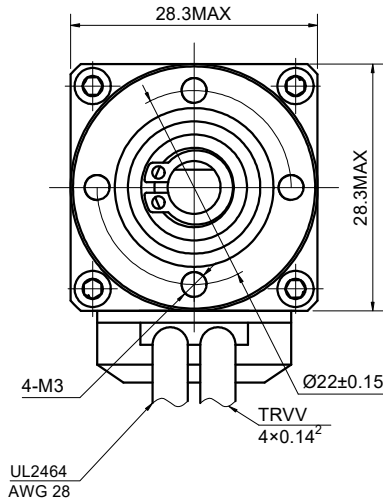

SPECIFICATION	CONNECTION	BIPOLAR
AMPS/PHASE		1.00
RESISTANCE/PHASE(Ohms)@25°C		3.50±10%
INDUCTANCE/PHASE(mH)@1KHz		3.20±20%
HOLDING TORQUE w/o GEARBOX(Nm)[lb-in]		0.14[1.24]
STEP ANGLE w/o GEARBOX(°)		1.80
GEAR RATIO		13 ²¹² / ₂₈₉
GEAR EFFICIENCY		80%
BACKLASH@NO-LOAD		<=3°
MAX.PERMISSIBLE TORQUE(Nm)		3
MOMENT PERMISSIBLE TORQUE(Nm)		5
AMBIENT TEMPERATURE		-10°C~50°C[14°F~122°F]
INSULATION CLASS		B 130°C[266°F]
TEMPERATURE RISE		MAX.80°C

COMMENT:

- 1.DYNAMIC AXIAL LOAD: 5N MAX
- 2.DYNAMIC RADIAL LOAD @ SHAFT LENGTH 20mm: 25N MAX
- 3.TMBF 6000h OR MORE @ 24V/300RPM
- 4.INSULATION RESISTANCE (NORMAL TEMPERATURE AND HUMIDITY): 100 Mohm
- 5.DIELECTRIC STRENGTH 500VAC FOR 1MIN.(BETWEEN THE MOTOR COILS AND THE MOTOR CASE)

MOTOR CONNECTION			
PIN NO	BIPOLAR	LEADS	WINDING
1	A+	BLK	
2	A-	GRN	
3	B+	RED	
4	B-	BLU	

ENCODER RESOLUTION:1000PPR(4000CPR)								
LEAD COLOR	RED	BLK	WHT	YEL	ORG	GRA	GRN	BLU
DESCRIPTION	VCC	GND	EA+	EA-	EB+	EB-	EZ+	EZ-

FULL STEP 2 PHASE-Ex.,WHEN FACING MOUNTING END (X)						CCW	CW	DIMENSIONS ARE IN MILLIMETERS. TOLERANCES AS BELOW: DECIMALS ANGLES X ±0.5 ±2° X.X ±0.25 X.XX ±0.13
STEP	A+	B+	A-	B-				
1	+	+	-	-				
2	-	+	+	-				
3	-	-	+	+				
4	+	-	-	+				

STEPPERONLINE®

STEPPER MOTOR

11HS20-1004D-E1000-PG14

THIS DOCUMENT SHALL NOT BE REPRODUCED NOR SHALL THE INFORMATION CONTAINED HEREIN BE USED BY OR DISCLOSED TO OTHERS UNLESS EXPRESSLY AUTHORIZED IN BY WRITING STEPPERONLINE.

SIGNATURE		DATE
DRN	HW	2.1.2024
APVD	LDJ	2.1.2024

REV.	0	SCALE	1:1	DWG NO.	A2868
------	---	-------	-----	---------	-------