

REV.	REVISION RECORD	BY	DATE
0	ORIGIN	LDJ	3.26.2024

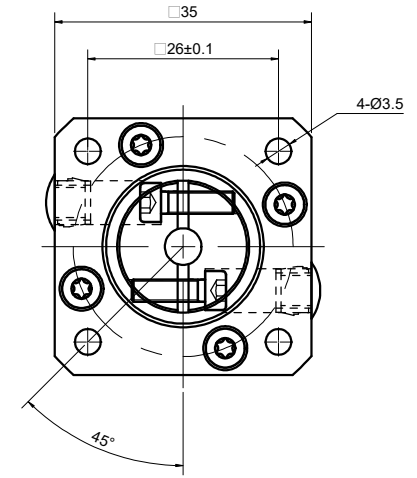
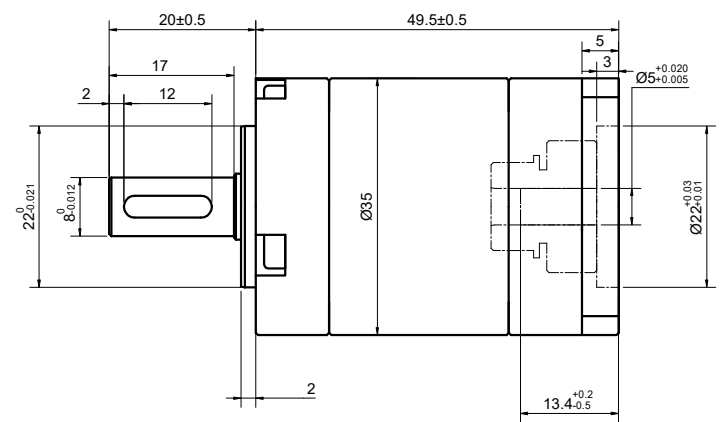
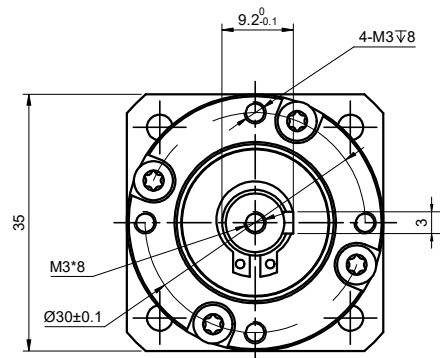

SPECIFICATION	CONNECTION	VALUE
GEAR RATIO		15
EFFICIENCY		94%
BACKLASH@NO-LOAD(arcmin)		<=20
MAX.PERMISSIBLE TORQUE(Nm)[lb-in]		9.00[79.66]
MOMENT PERMISSIBLE TORQUE(Nm)[lb-in]		18.00[159.32]
SHAFT MAXIMUM AXIAL LOAD(N)		100
SHAFT MAXIMUM RADIAL LOAD(N)		270
GEARBOX MATCHING MOTOR'S INPUT SHAFT LENGTH (mm)		6.5~10
RATED INPUT SPEED(RPM)		1000
MAX. INPUT SPEED(RPM)		2000
NOISE(dB)		<=55
WATERPROOF RATING		IP54
LIFE(h)		20000
WORKING TEMPERATURE		-20°C~150°C[-4°F~302°F]

DIMENSIONS ARE IN MILLIMETERS.
 TOLERANCES AS BELOW:
 DECIMALS ANGLES
 X ±0.5 ±2°
 X.X ±0.25
 X.XX ±0.13

THIRD ANGLE PROJECTION		
SIGNATURE		DATE
DRN	LDJ	3.26.2024
APVD	HW	3.26.2024

STEPPERONLINE®

GEARBOX

EGS14-G15

REV.	1	SCALE	1:1	DWG NO.	A3063
------	---	-------	-----	---------	-------