

REV.	REVISION RECORD	BY	DATE
0	ORIGIN	YSX	3.1.2024

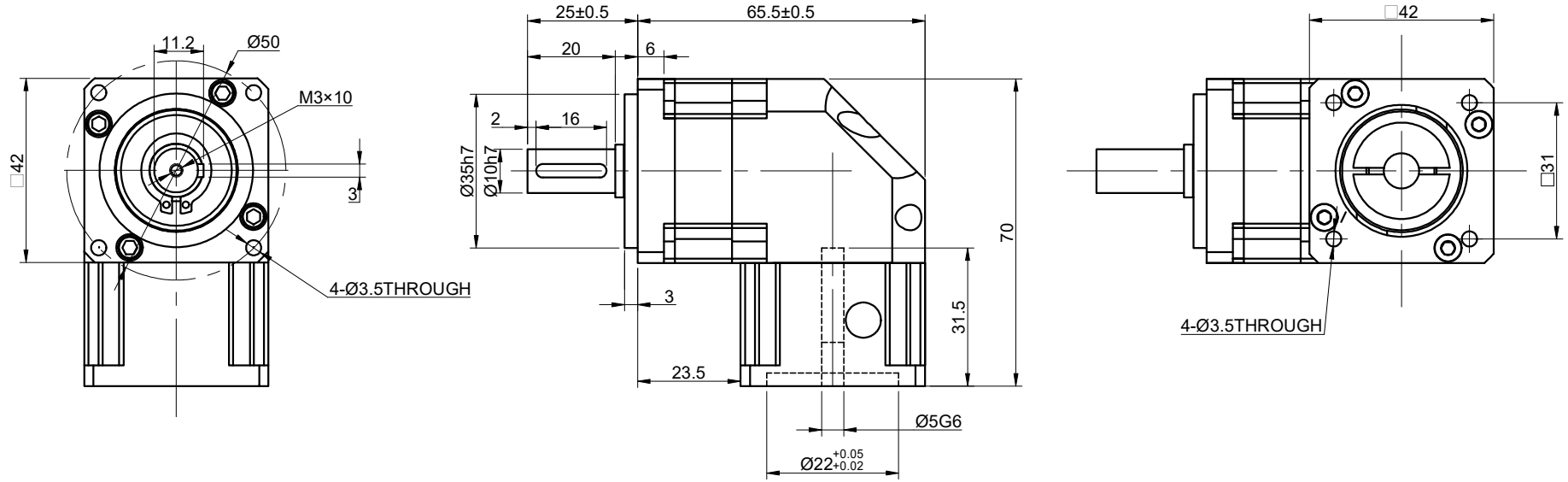

SPECIFICATION	CONNECTION	VALUE
GEAR RATIO		5
EFFICIENCY		96%
BACKLASH@NO-LOAD(arcmin)		<=15
MAX.PERMISSIBLE TORQUE(Nm)[lb-in]		9[79.66]
MOMENT PERMISSIBLE TORQUE(Nm)[lb-in]		18[159.31]
SHAFT MAXIMUM AXIAL LOAD(N)		80
SHAFT MAXIMUM RADIAL LOAD(N)		260
GEARBOX MATCHING MOTOR'S INPUT SHAFT LENGTH (mm)		15-30
RATED INPUT SPEED(RPM)		3000
MAX. INPUT SPEED(RPM)		6000
NOISE(dB)		<=60
WATERPROOF RATING		IP54
LIFE(h)		20000
WORKING TEMPERATURE		-10°C~90°C[14°F~212°F]

DIMENSIONS ARE IN MILLIMETERS.  
TOLERANCES AS BELOW:  
DECIMALS ANGLES  
X ±0.5 ±2°  
X.X ±0.25  
X.XX ±0.13

THIRD ANGLE PROJECTION		
SIGNATURE		DATE
DRN	YSX	3.1.2024
APVD	LDJ	3.1.2024

**STEPPERONLINE®**

**GEARBOX**

**RYG17-G05**

REV.	0	SCALE	1:1	DWG NO.	A2947
------	---	-------	-----	---------	-------