

CUSTOMER'S MODEL: NO MODEL
 END COVER COLOR: GRAY

REV.	REVISION RECORD	BY	DATE
0	ORIGIN	ZPJ	11.23.2023

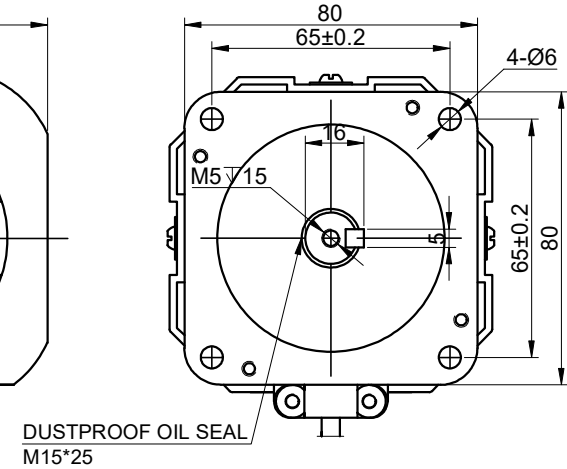
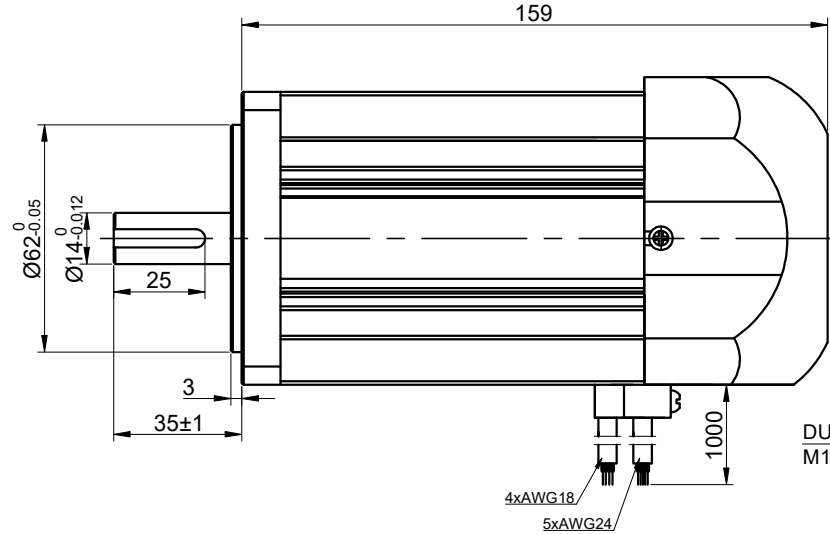
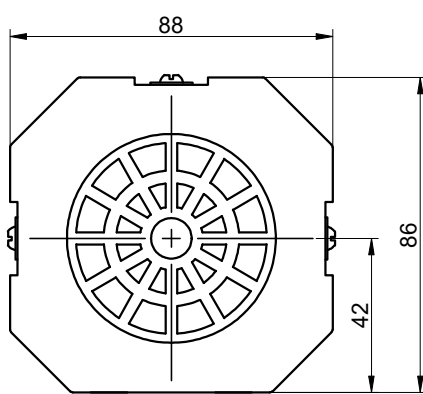

SPECIFICATION	VALUE
NO. of PHASES	3
NO. of POLES	4
RESISTANCE/PHASE(Ohms)@25°C	1.94±10%
INDUCTANCE/PHASE(mH)@1KHz	6.90±20%
RATED VOLTAGE(V)	310VDC
RATED TORQUE(mN.m)	1.75
RATED POWER(W)	1100
RATED SPEED(RPM)	6000±10%
RATED CURRENT(A)	4.5±10%
Ke(V/krpm)	30
SENSOR	HALL
AMBIENT TEMPERATURE	-10°C~50°C[14°F~122°F]
INSULATION CLASS	B 130°C[266°F]
TEMPERATURE RISE	MAX.80°C

COMMENT:
 1.DYNAMIC AXIAL LOAD: 10N MAX
 2.DYNAMIC RADIAL LOAD @ SHAFT LENGTH 20mm: 20N MAX
 3.INSULATION RESISTANCE (NORMAL TEMPERATURE AND HUMIDITY): 100 Mohm
 4.DIELECTRIC STRENGTH: AC600V CUT OFF CURRENT 5mA FOR 1S

DIMENSIONS ARE IN MILLIMETERS.
 TOLERANCES AS BELOW:
 DECIMALS ANGLES
 X ±0.5 ±2°
 X.X ±0.25
 X.XX ±0.13

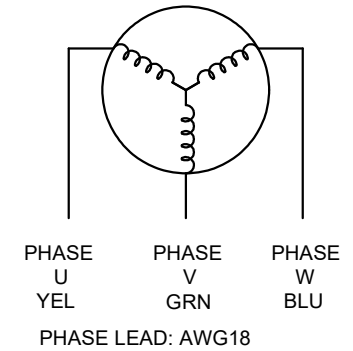
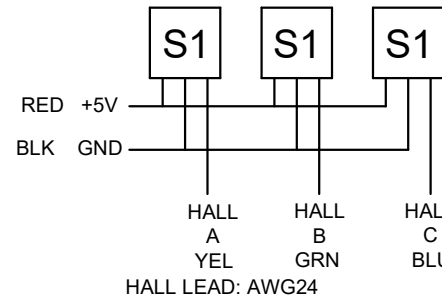

STEPPERONLINE®

BRUSHLESS MOTOR

80BLS160F-310-02

THIS DOCUMENT SHALL NOT BE REPRODUCED NOR SHALL THE INFORMATION CONTAINED HEREIN BE USED BY OR DISCLOSED TO OTHERS UNLESS EXPRESSLY AUTHORIZED IN BY WRITING STEPPERONLINE.

SIGNATURE		DATE
DRN	ZPJ	11.23.2023
APVD	LDJ	11.24.2023

REV.	0	SCALE	1:3	DWG NO.	A2627
------	---	-------	-----	---------	-------