

SPEED - TORQUE CURVE

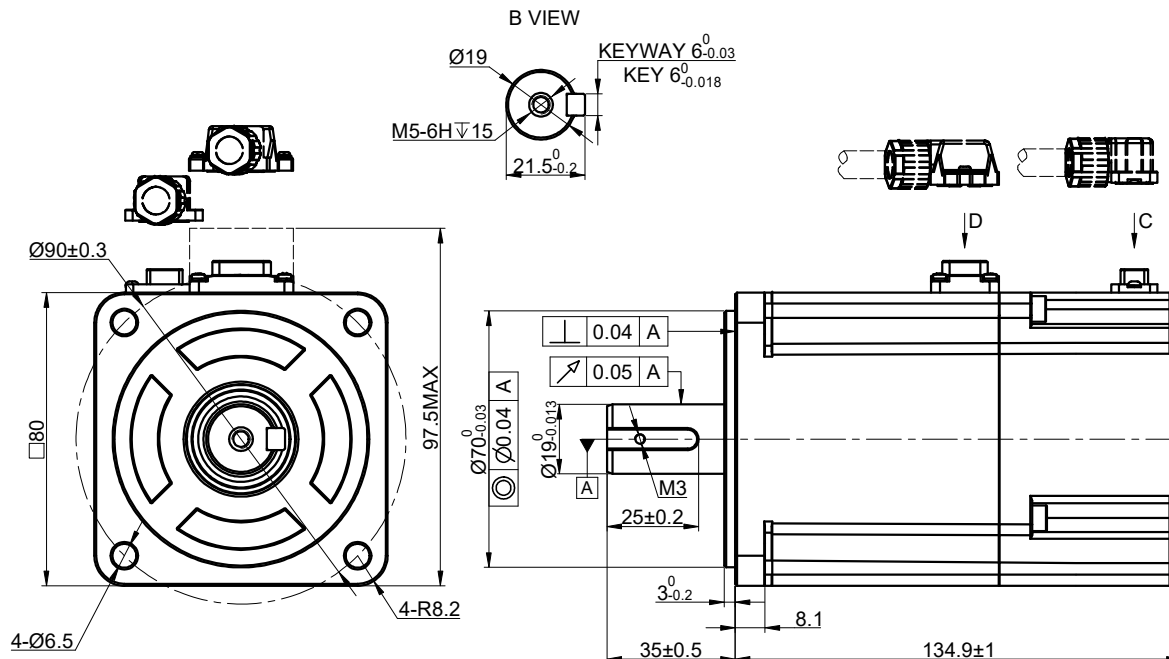
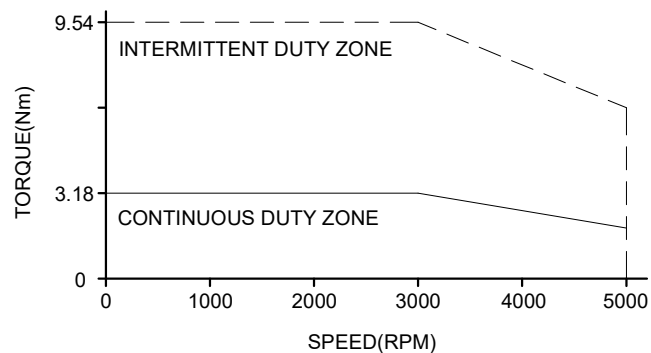

SPECIFICATION	VALUE
RATED VOLTAGE(VAC)	220
RATED POWER(W)	1000
RATED TORQUE(Nm)	3.18
PEAK TORQUE(Nm)	9.54
RATED SPEED(RPM)	3000
PEAK SPEED(RPM)	5000
RATED CURRENT(Amp)	5.7
PEAK CURRENT(Amp)	17.7
TORQUE CONST(Nm/Amp)	0.56
BACK EMF CONST(V/KRPM)	38.3
RESISTANCE(Ω)	1.08
INDUCTANCE(mH)	5.6
INERTIA(Kg·m ² ·10 ⁻⁴)	2.15
POLES	10
ENCODER TYPE	23bit magnetic
IP RATING	IP67
WEIGHT(KG)	3.4

WIRING DETAILS OF POWER CABLE CONNECTOR							
	PIN No.	1	2	3	4	A	B
	DESCRIPTION	U	V	W	PE	0V	24V
	COLOR	BLK	WHT	RED	YEL/GRE	BLU	BLU

WIRING DETAILS OF ENCODER CABLE CONNECTOR								
	PIN No.	1	2	3	4	5	6	7
	DESCRIPTION	PE	5V	0V	SD+	SD-	BAT+	BAT-
	COLOR	SHIELD	RED	BLK	BLU	YEL	BRN	WHT

THE PART NUMBER OF CABLE FOR T6M80-1000H2B1-M23 MOTOR		
POWER CABLE	CMST1M5-2	AWG 21
ENCODER CABLE	CEST1M5-2	AWG 25



	APVD	LDJ	11.1.2023
	CHKD		
2:1	DRN	ZPJ	11.1.2023
SCALE	SIGNATURE		DATE

AC SERVO MOTOR
T6M80-1000H2B1-M23