

MODEL NO. 23HS45-4204S1 DWG NO. A2292

CUSTOMER'S MODEL: NO MODEL
END COVER COLOR: BLACK

REV.	REVISION RECORD	BY	DATE
0	ORIGIN	LDJ	6.30.2023

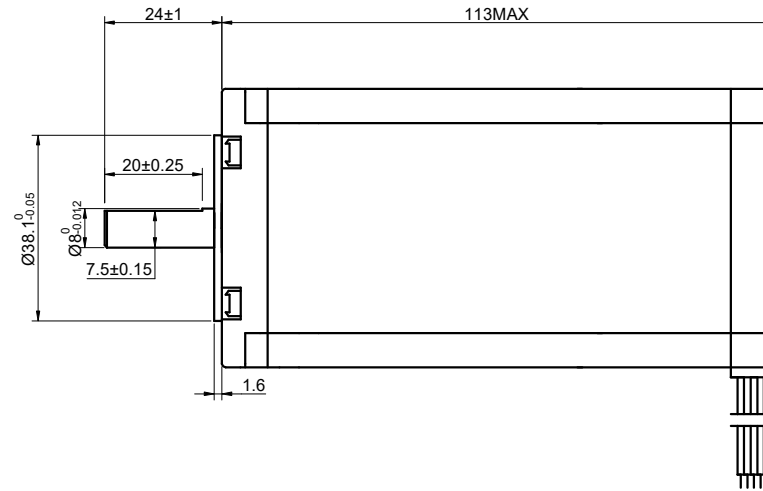
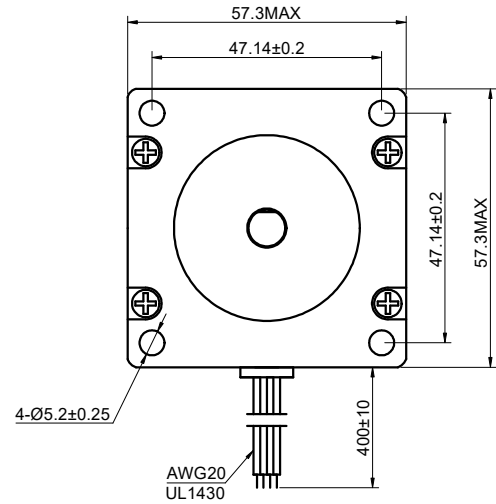

CONNECTION	BIPOLAR
SPECIFICATION	BIPOLAR
AMPS/PHASE	4.20
RESISTANCE/PHASE(Ohms)@25°C	0.88±10%
INDUCTANCE/PHASE(mH)@1KHz	3.40±20%
HOLDING TORQUE(Nm)[lb-in]	3.00[26.55]
STEP ANGLE(°)	1.80
STEP ACCURACY(NON-ACCUM)	±5.00%
ROTOR INERTIA(g-cm²)	340
WEIGHT(Kg)[lb]	—
AMBIENT TEMPERATURE	-10°C~50°C[14°F~122°F]
INSULATION CLASS	B 130°C[266°F]
TEMPERATURE RISE	MAX.80°C

COMMENT:

- 1.DYNAMIC AXIAL LOAD: 15N MAX
- 2.DYNAMIC RADIAL LOAD @ SHAFT LENGTH 20mm: 75N MAX
- 3.TMBF 6000h OR MORE @ 24V/300RPM
- 4.INSULATION RESISTANCE (NORMAL TEMPERATURE AND HUMIDITY): 100 Mohm
- 5.DIELECTRIC STRENGTH 500VAC FOR 1MIN.(BETWEEN THE MOTOR COILS AND THE MOTOR CASE)

MOTOR CONNECTION			
PIN NO	BIPOLAR	LEADS	WINDING
1	A+	BLK	
2	A-	GRN	
3	B+	RED	
4	B-	BLU	

FULL STEP 2 PHASE-Ex.,WHEN FACING MOUNTING END (X)					CCW	CW	DIMENSIONS ARE IN MILLIMETERS. TOLERANCES AS BELOW: DECIMALS ANGLES X ±0.5 ±2° X.X ±0.25 X.XX ±0.13
STEP	A+	B+	A-	B-			
1	+	+	-	-			
2	-	+	+	-			
3	-	-	+	+			
4	+	-	-	+			

STEPPERONLINE®

STEPPER MOTOR

SIGNATURE		DATE
DRN	LDJ	6.30.2023
APVD	YSX	6.30.2023

23HS45-4204S1

REV.	0	SCALE	2:3	DWG NO.	A2292
------	---	-------	-----	---------	-------