

4522V ON GMD 001G-099L ON TEGOW

CUSTOMER'S MODEL: NO MODEL
END COVER COLOR: BLACK

REV.	REVISION RECORD	BY	DATE
0	ORIGIN	YSX	6.15.2023

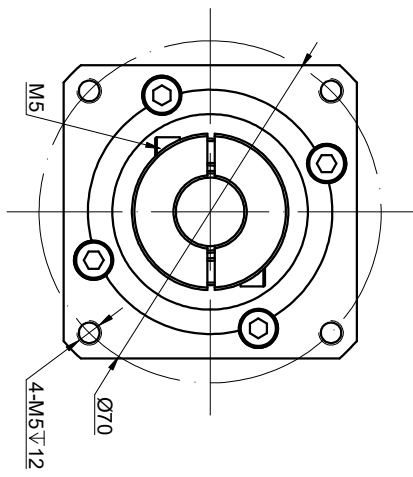
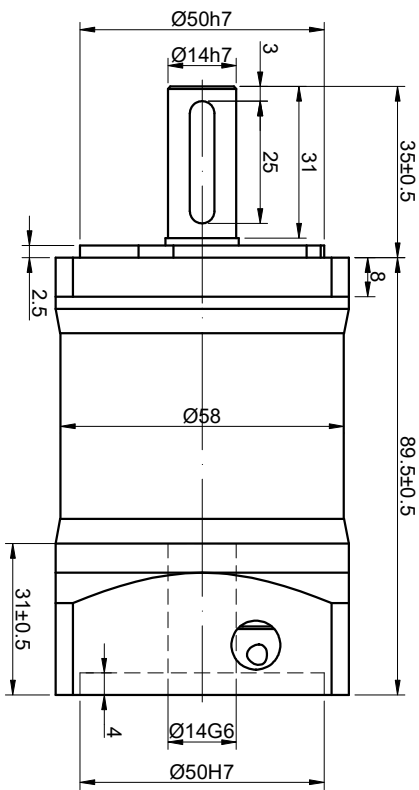
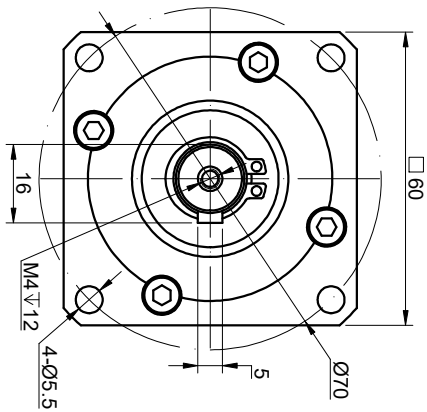

SPECIFICATION	CONNECTION	BIPOLAR
GEAR RATIO		100
EFFICIENCY		94.00%
BACKLASH@NO.LOAD(arcmin)		<=15
MAX.PERMISSIBLE TORQUE(Nm)[lb-in]		10.00[88.51]
MOMENT PERMISSIBLE TORQUE(Nm)[lb-in]		20.00[177.01]
SHAFT MAXIMUM AXIAL LOAD(N)		230
SHAFT MAXIMUM RADIAL LOAD(N)		450
INPUT SHAFT LENGTH (mm)		30
RATED INPUT SPEED(RPM)		3000
NOISE(dB)		<=55
WATERPROOF RATING		IP54
LIFE(h)		20000
WORKING TEMPERATURE		-20°C~150°C[-4°F~302°F]

THIS DOCUMENT SHALL NOT BE REPRODUCED NOR SHALL THE INFORMATION CONTAINED HEREIN BE USED BY OR DISCLOSED TO OTHERS UNLESS EXPRESSLY AUTHORIZED IN BY WRITING STEPPERONLINE.

DIMENSIONS ARE IN MILLIMETERS.
TOLERANCES AS BELOW:

DECIMALS ±0.5
X.X ±0.25
X.XX ±0.13

ANGLES ±2°

THIRD ANGLE PROJECTION		DATE
SIGNATURE		6.15.2023
DRN	YSX	6.15.2023
APVD	ZPJ	6.16.2023

STEPPERONLINE®

PLANETARY GEARBOX

TG60-G100

REV.	1	SCALE	2: 3	DWG NO.	A2257
------	---	-------	------	---------	-------