

END COVER COLOR : BLACK

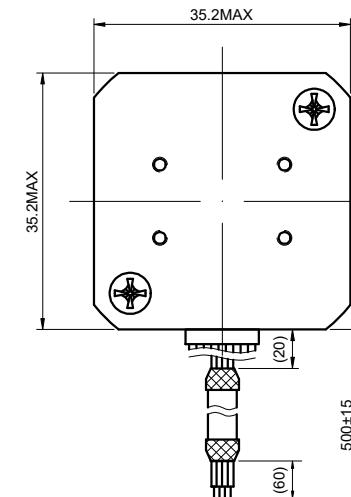
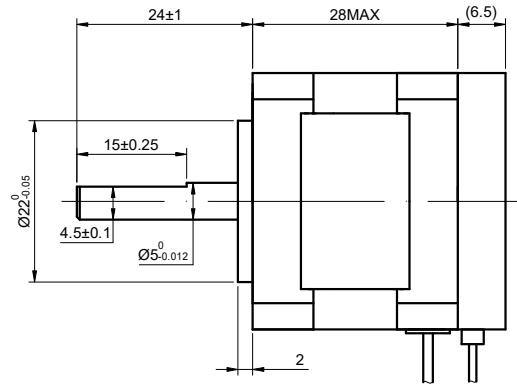
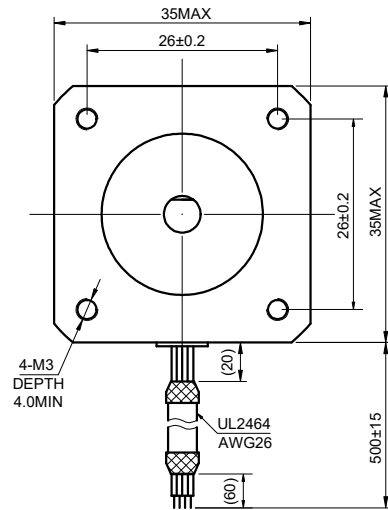

SPECIFICATION	CONNECTION	BIPOLAR
AMPS/PHASE		1.00
RESISTANCE/PHASE(Ohms)@25°C		3.50±10%
INDUCTANCE/PHASE(mH)@1KHz		3.50±20%
HOLDING TORQUE (Nm)[lb-in]		0.125[1.11]
STEP ANGLE(°)		1.80
STEP ACCURACY(NON-ACCUM)		±5.00%
WEIGHT(Kg)[lb]		—
TEMPERATURE RISE:MAX.80°C (MOTOR STANDSTILL;FOR 2PHASE ENERGIZED)		
AMBIENT TEMPERATURE -10°C~50°C[14°F~122°F]		
INSULATION RESISTANCE 100 Mohm (UNDER NORMAL TEMPERATURE AND HUMIDITY)		
INSULATION CLASS B 130°C[266°F]		
DIELECTRIC STRENGTH 500VAC FOR 1MIN.(BETWEEN THE MOTOR COILS AND THE MOTOR CASE)		

TYPE OF CONNECTION (EXTERN)		MOTOR	
PIN NO	BIPOLAR	LEADS	WINDING
1	A+ —	BLK	A+
2	A- —	GRN	A-
3	B+ —	RED	B+
4	B- —	BLU	B-

FULL STEP 2 PHASE-Ex. ,
WHEN FACING MOUNTING END (X)

STEP	A+	B+	A-	B-		CCW
1	+	+	-	-	↓ ↑	↑ ↓
2	-	+	+	-		
3	-	-	+	+		
4	+	-	-	+		

ENCODER CONNECTION:1000PPR(4000CPR)								
LEAD COLOR	RED	BLK	BRN	ORG	BLU	GRN	YEL	PUR
DESCRIPTION	+5V	EGND	EA+	EA-	EB+	EB-	EZ+	EZ-



APVD		12.9.2022
CHKD		
1:1	DRN	
SCALE	SIGNATURE	DATE

STEPPER MOTOR
14HS11-1004-ME1K