

AMP 172169-1
TERMINAL AMP-170360-1

AMP 172167-1
TERMINAL AMP-170360-1

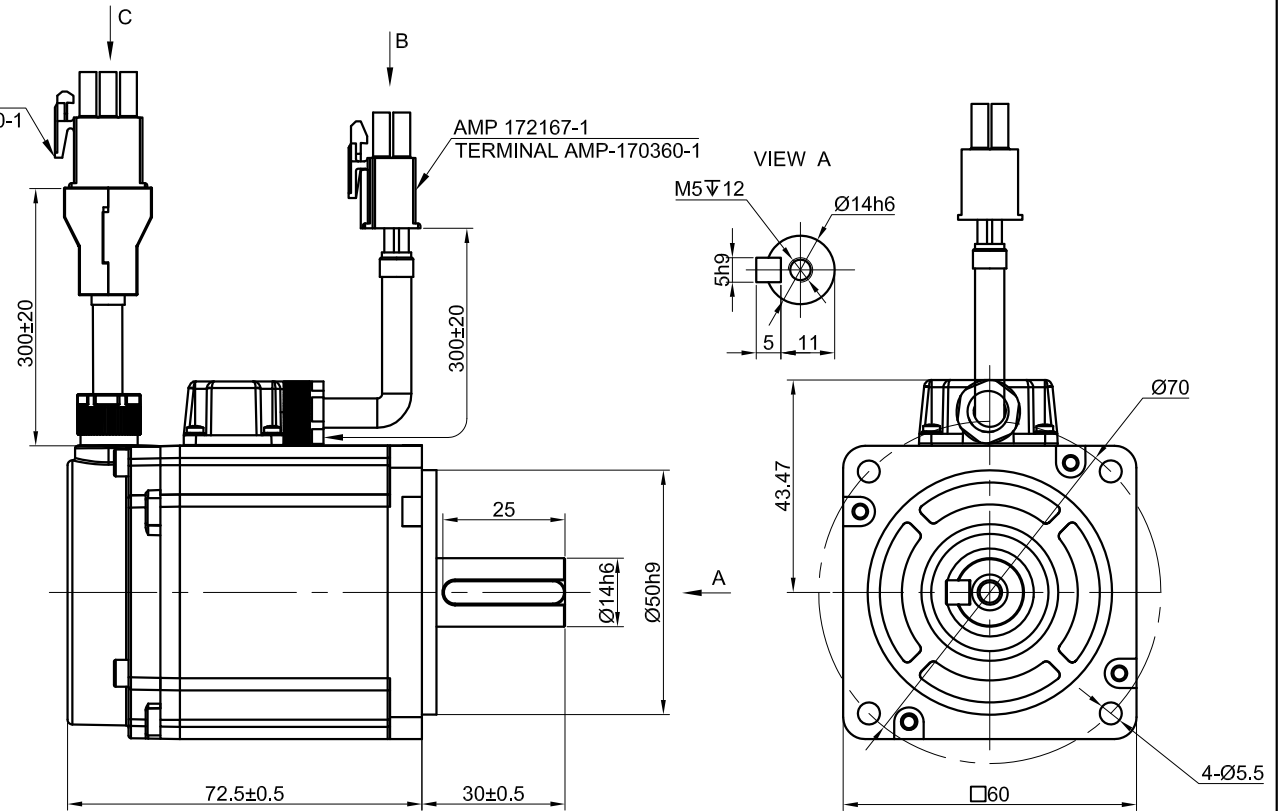

SPECIFICATION	VALUE
RATED VOLTAGE(VAC)	220
COUNTER POTENTIAL(V/1000r/min)	23.5
RATED POWER(W)	200
RATED TORQUE(Nm)	0.64
PEAK TORQUE(Nm)	1.92
RATED SPEED(RPM)	3000
PEAK SPEED(RPM)	6500
RATED CURRENT(Amp)	1.4
PEAK CURRENT(Amp)	6.2
NUMBER OF STATOR SLOTS(S)	12
INSULATION CLASS	F
RESISTANCE(Ω)	3.34
INDUCTANCE(mH)	0.56
INERTIA(Kg•m ² •10 ⁻⁴)	0.29
POLES	5
ENCODER TYPE	17bit inc
IP RATING	IP65

VIEW B	WIRING DETAILS OF POWER CABLE CONNECTOR				
	PIN No.	1	2	3	4
	DESCRIPTION	U	V	W	PE
	COLOR	RED	WHT	BLK	YEL/GRE

VIEW C	WIRING DETAILS OF ENCODER CABLE CONNECTOR									
	PIN No.	1	2	3	4	5	6	7	8	9
	DESCRIPTION	FG	+5V	0V	—	—	—	SD+	—	SD-
	COLOR	SHIELD	RED	BLK	—	—	—	BLU	—	YEL

STEPPERONLINE®

	APVD		1.11.2023
	CHKD		
2:1	DRN		
SCALE	SIGNATURE		DATE

AC SERVO MOTOR
E6M60-200H2A2-M17S