

NUT MATERIAL: POM(BLACK)

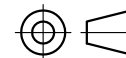
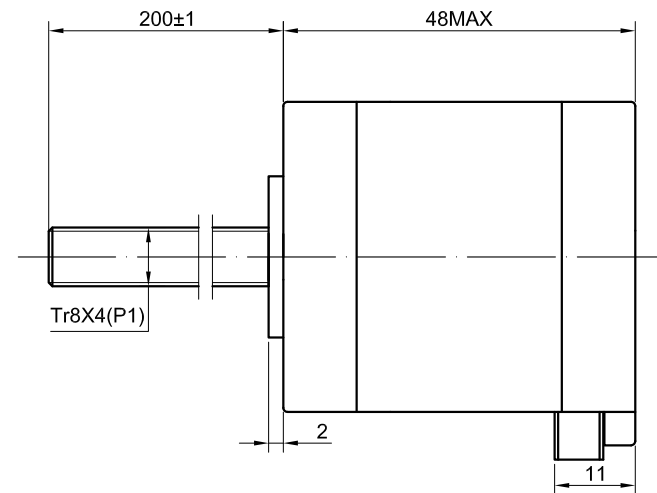
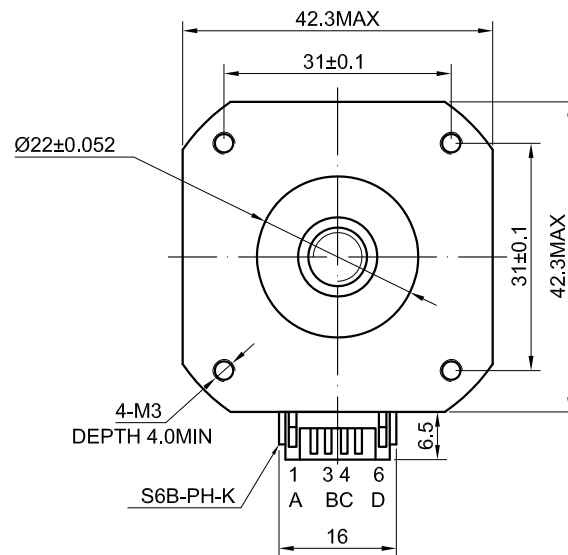
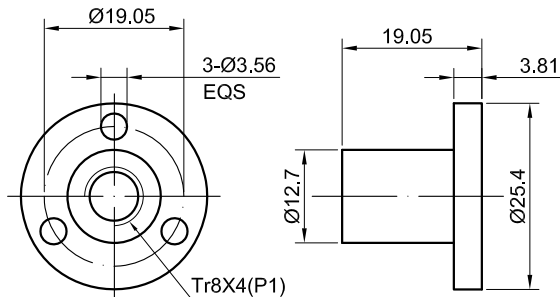

SPECIFICATION	CONNECTION	BIPOLAR
AMPS/PHASE		1.68
RESISTANCE/PHASE(Ohms)@25°C		1.65±10%
INDUCTANCE/PHASE(mH)@1KHz		2.80±20%
HOLDING TORQUE(Nm)[lb-in]		0.44[3.89]
LINEAR TRAVEL/STEP(mm)		0.01
STEP ANGLE(°)		1.80
STEP ACCURACY(NON-ACCUM)		±5.00%
ROTOR INERTIA(g-cm²)		82.00
WEIGHT(Kg)[lb]		—
TEMPERATURE RISE:MAX.80°C (MOTOR STANDSTILL;FOR 2PHASE ENERGIZED)		
AMBIENT TEMPERATURE -10°C~50°C[14°F~122°F]		
INSULATION RESISTANCE 100 Mohm (UNDER NORMAL TEMPERATURE AND HUMIDITY)		
INSULATION CLASS B 130°C[266°F]		
DIELECTRIC STRENGTH 500VAC FOR 1MIN.(BETWEEN THE MOTOR COILS AND THE MOTOR CASE)		

TYPE OF CONNECTION (EXTERN)		MOTOR	
PIN NO	BIPOLAR	LEADS	WINDING
1	A —	RED	A
2	C —	GRY	C
3	B —	YEL	B
4	D —	GRN	D

FULL STEP 2 PHASE-Ex. ,
WHEN FACING MOUNTING END (X)

STEP	A	B	C	D		CCW
1	+	+	-	-	↓	↑
2	-	+	+	-		
3	-	-	+	+		
4	+	-	-	+		
						CW

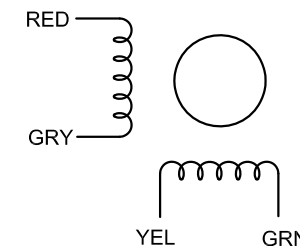

STEPPERONLINE®

	APVD		11.17.2022
	CHKD		
1:1	DRN		
SCALE	SIGNATURE		DATE

STEPPER MOTOR

17LS19-1684E-200H