

MODEL NO. 86IBL400-4830 DWG NO. A2678

CUSTOMER'S MODEL: NO MODEL
END COVER COLOR: BLACK

REV.	REVISION RECORD	BY	DATE
0	ORIGIN	ZPJ	12.7.2023

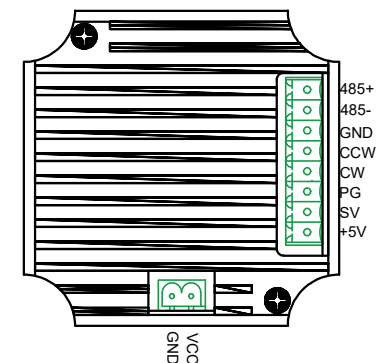
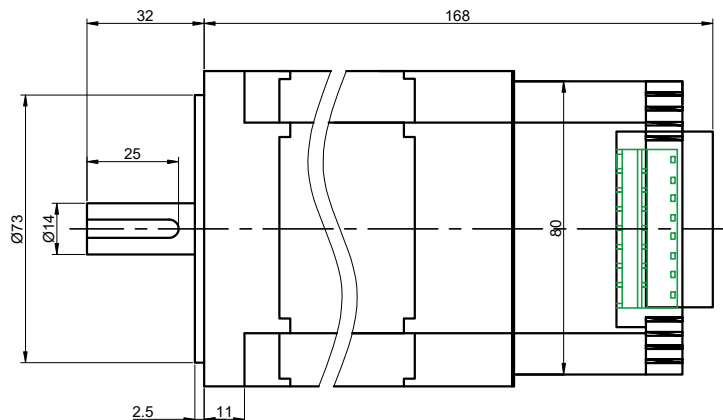
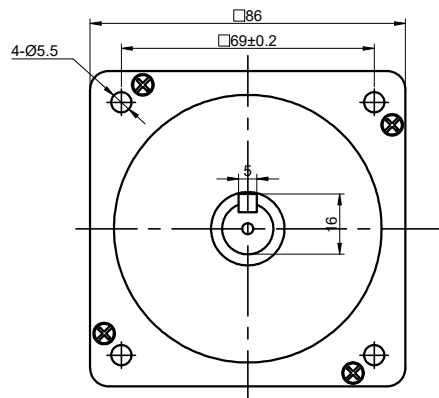

SPECIFICATION	VALUE
NO. of PHASES	3
NO. of POLES	8
RESISTANCE/PHASE(Ohms)@25°C	0.21±10%
INDUCTANCE/PHASE(mH)@1KHz	0.51±20%
RATED VOLTAGE(VDC)	48
RATED TORQUE(N.m)	1.27
RATED POWER(W)	400
RATED SPEED(RPM)	3000±10%
RATED CURRENT(A)	8.33±10%
Ke(V/krpm)	14.2
SENSOR	HALL
AMBIENT TEMPERATURE	-10°C~50°C[14°F~122°F]
INSULATION CLASS	B 130°C[266°F]
TEMPERATURE RISE	MAX.80°C

COMMENT:
1.DYNAMIC AXIAL LOAD: --N MAX
2.DYNAMIC RADIAL LOAD @ SHAFT LENGTH 20mm: --N MAX
3.INSULATION RESISTANCE
(NORMAL TEMPERATURE AND HUMIDITY): 100 Mohm
4.DIELECTRIC STRENGTH: AC600V CUT OFF CURRENT 5mA FOR 1S

DIMENSIONS ARE IN MILLIMETERS.
TOLERANCES AS BELOW:
DECIMALS ANGLES
X ±0.5 ±2°
X.X ±0.25
X.XX ±0.13

THIRD ANGLE PROJECTION

STEPPERONLINE®

INTEGRATED BRUSHLESS MOTOR

86IBL400-4830

THIS DOCUMENT SHALL NOT BE REPRODUCED NOR SHALL THE INFORMATION CONTAINED HEREIN BE USED BY OR DISCLOSED TO OTHERS UNLESS EXPRESSLY AUTHORIZED IN BY WRITING STEPPERONLINE.

SIGNATURE		DATE
DRN	ZPJ	12.7.2023
APVD	LDJ	12.7.2023

REV.	0	SCALE	1:3	DWG NO.	A2678
------	---	-------	-----	---------	-------