

END COVER COLOR : BLACK

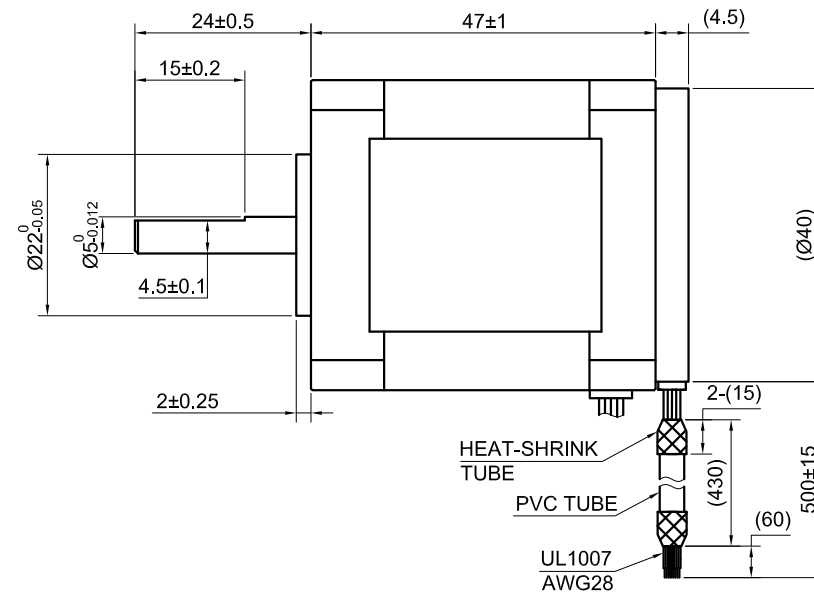
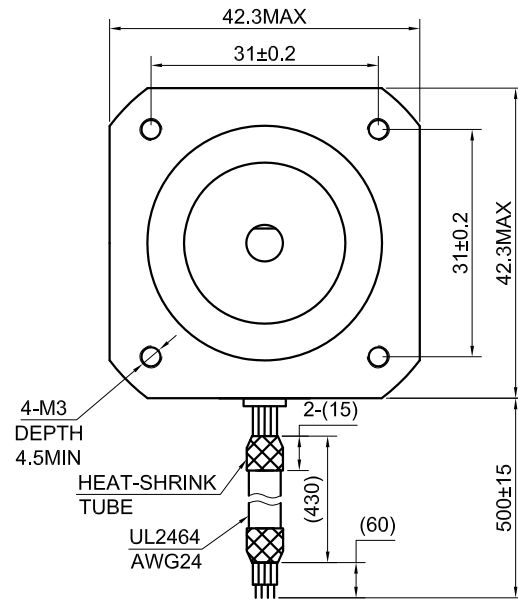

SPECIFICATION	CONNECTION	BIPOLAR
AMPS/PHASE		2.00
RESISTANCE/PHASE(Ohms)@25°C		1.40±10%
INDUCTANCE/PHASE(mH)@1KHz		3.00±20%
HOLDING TORQUE(Nm)[lb-in]		0.56[4.96]
STEP ANGLE(°)		1.80
STEP ACCURACY(NON-ACCUM)		±5.00%
ROTOR INERTIA(g-cm ²)		75.00
WEIGHT(Kg)[lb]		—
TEMPERATURE RISE:MAX.80°C (MOTOR STANDSTILL;FOR 2PHASE ENERGIZED)		
AMBIENT TEMPERATURE -10°C~50°C[14°F~122°F]		
INSULATION RESISTANCE 100 Mohm (UNDER NORMAL TEMPERATURE AND HUMIDITY)		
INSULATION CLASS B 130°C[266°F]		
DIELECTRIC STRENGTH 500VAC FOR 1MIN.(BETWEEN THE MOTOR COILS AND THE MOTOR CASE)		
AMBIENT HUMIDITY MAX.85%(NO CONDENSATION)		

TYPE OF CONNECTION (EXTERN)		MOTOR	
PIN NO	BIPOLAR	LEADS	WINDING
1	A+ —	RED	A+
2	A- —	BLK	A-
3	B+ —	YEL	B+
4	B- —	BLU	B-

FULL STEP 2 PHASE-Ex. ,
WHEN FACING MOUNTING END (X)

STEP	A+	B+	A-	B-		CW
1	+	+	-	-	↓ ↑	↑ ↓
2	-	+	+	-		
3	-	-	+	+		
4	+	-	-	+		

ENCODER CONNECTION:1000PPR(4000CPR)								
LEAD COLOR	RED	BLK	BRN	ORG	BLU	GRN	YEL	WHT
DESCRIPTION	VCC	EGND	EA+	EA-	EB+	EB-	EZ+	EZ-



APVD		11.26.2021
CHKD		
1:1	DRN	
SCALE	SIGNATURE	DATE

STEPPER MOTOR
17HS19-2004-ME1K