

REV.	REVISION RECORD	BY	DATE
0	ORIGIN	HW	3.7.2024

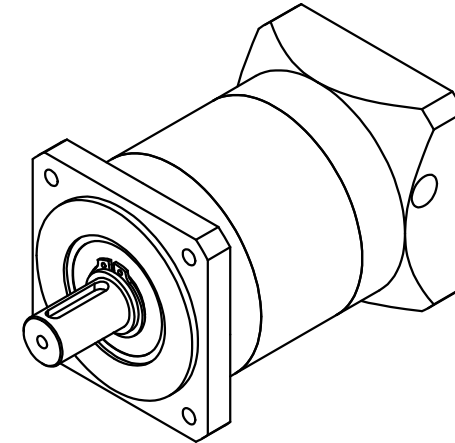
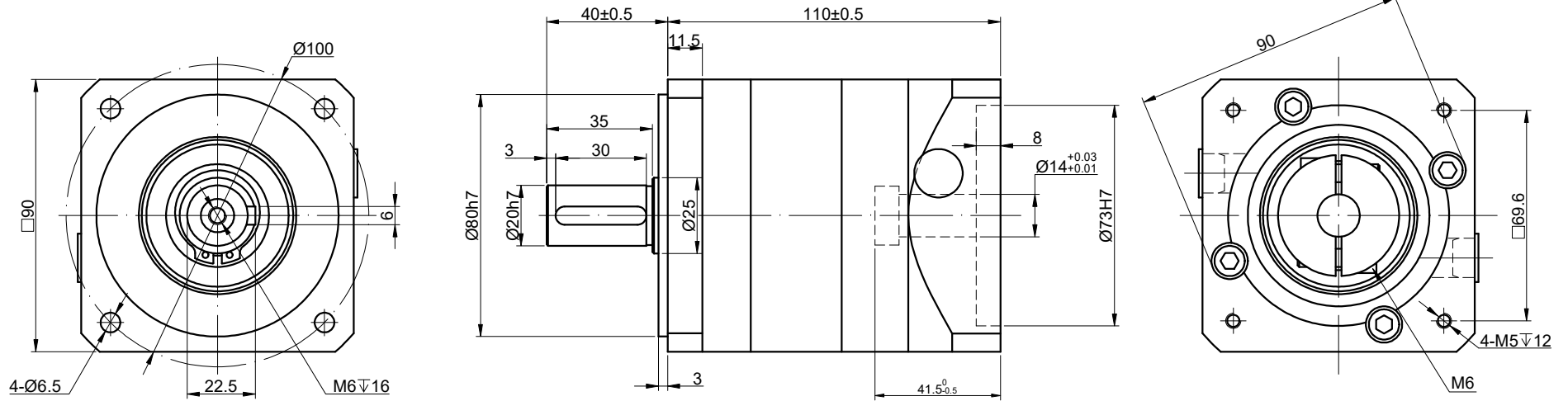

SPECIFICATION	CONNECTION	VALUE
GEAR RATIO		5
EFFICIENCY		96%
BACKLASH@NO-LOAD(arcmin)		<=15
MAX.PERMISSIBLE TORQUE(Nm)[lb-in]		90.00[796.57]
MOMENT PERMISSIBLE TORQUE(Nm)[lb-in]		180.00[1593.13]
SHAFT MAXIMUM AXIAL LOAD(N)		800
SHAFT MAXIMUM RADIAL LOAD(N)		1000
GEARBOX MATCHING MOTOR'S INPUT SHAFT LENGTH (mm)		22-41
RATED INPUT SPEED(RPM)		3000
MAX. INPUT SPEED(RPM)		6000
NOISE(dB)		<=65
WATERPROOF RATING		IP54
LIFE(h)		20000
WORKING TEMPERATURE		-20°C~150°C[-4°F~302°F]

DIMENSIONS ARE IN MILLIMETERS.
TOLERANCES AS BELOW:
DECIMALS ANGLES
X ±0.5 ±2°
X.X ±0.25
X.XX ±0.13

THIRD ANGLE PROJECTION		
SIGNATURE		DATE
DRN	HW	3.7.2024
APVD	LDJ	3.11.2024

PLANETARY GEARBOX									
EG34-G5									
REV.	0	SCALE	1:2	DWG NO.	A1801				