

SPECIFICATION	VALUE
NO. of PHASES	3
NO. of POLES	4
RATED VOLTAGE(V)	24
RATED CURRENT(A)	14.0±10%
RATED POWER(W)	220
RATED SPEED w/o GEARBOX(RPM)	3500±10%
RATED TORQUE(N.m)	25
GEAR RATIO	100
EFFICIENCY	65.00%REF
MAX.PERMISSIBLE TORQUE(Nm)[lb-in]	25[221.27]
BACKLASH@NO-LOAD(°)	2.4
SENSOR	HALL SENSOR
INSULATION CLASS	CLASS B
INSULATION RESISTANCE	100MΩ MIN @ 500VDC
DIELECTRIC STRENGTH TEST	500VDC for 1 MINUTE
BEARING TYPE	NMB BALL BEARING. C3

HALL LEAD: UL1007 26AWG

PHASE LEAD: UL1007 18AWG

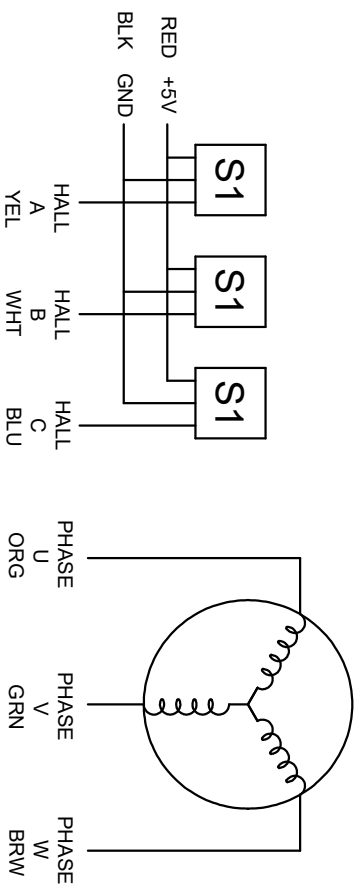

	APVD		<h2>BRUSHLESS DC MOTOR</h2> <p>57BLR90-24-01-HG100</p>
	CHKD		
	DRN	12.8.2023	
SCALE	1.5:1	SIGNATURE	DATE