

| SPECIFICATION                     | VALUE                |
|-----------------------------------|----------------------|
| NO. of PHASES                     | 3                    |
| NO. of POLES                      | 4                    |
| RATED VOLTAGE(V)                  | 24                   |
| RATED CURRENT(A)                  | 10.4±10%             |
| RATED POWER(W)                    | 172                  |
| RATED SPEED w/o GEARBOX(RPM)      | 3500±10%             |
| RATED TORQUE (N.m)                | 17.63                |
| GEAR RATIO                        | 50                   |
| EFFICIENCY                        | 75.00%REF            |
| MAX.PERMISSIBLE TORQUE(Nm)[lb-in] | 20[177.01]           |
| BACKLASH@NO-LOAD(°)               | 1.6                  |
| SENSOR                            | HALL SENSOR          |
| INSULATION CLASS                  | CLASS B              |
| INSULATION RESISTANCE             | 100MΩ MIN @ 500VDC   |
| DIELECTRIC STRENGTH TEST          | 500VDC for 1 MINUTE  |
| BEARING TYPE                      | NMB BALL BEARING, C3 |

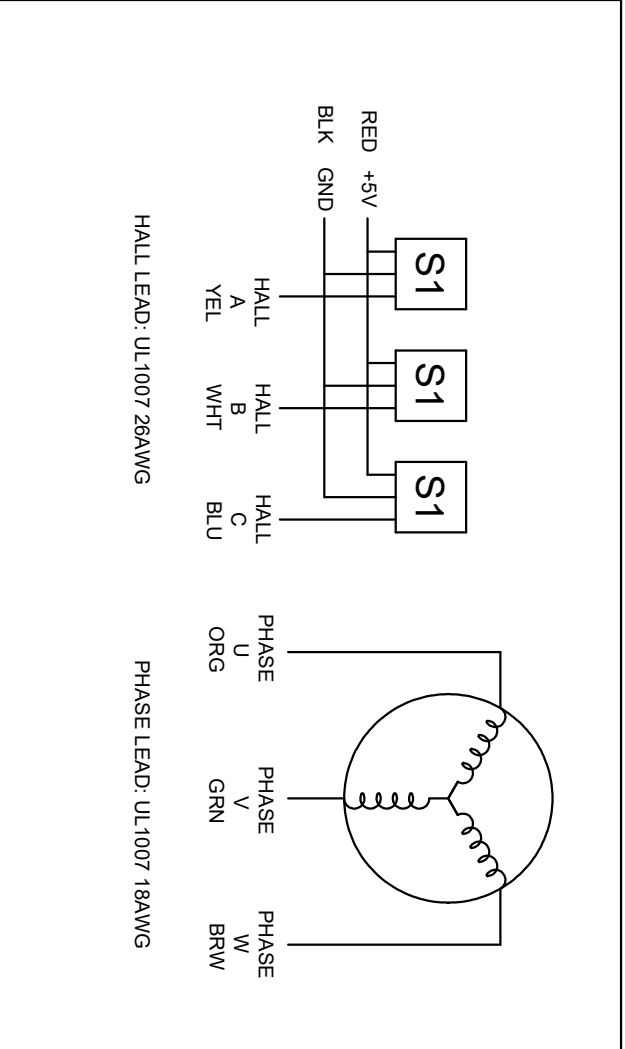

|       |  |           |  |                    |
|-------|--|-----------|--|--------------------|
|       |  | APVD      |  | BRUSHLESS DC MOTOR |
|       |  | CHKD      |  |                    |
| SCALE |  | DRN       |  | 57BLR70-24-02-HG50 |
| 1.5:1 |  | SIGNATURE |  |                    |
|       |  | DATE      |  |                    |
|       |  | 12.8.2023 |  |                    |