

SPECIFICATION	VALUE
NO. of PHASES	3
NO. of POLES	4
RATED VOLTAGE(V)	24
RATED CURRENT(A)	10.4±10%
RATED POWER(W)	172
RATED SPEED w/o GEARBOX(RPM)	3500±10%
RATED TORQUE (N.m)	4.00
GEAR RATIO	10
EFFICIENCY	85.00%REF
MAX.PERMISSIBLE TORQUE(Nm)[lb-in]	6[53.10]
BACKLASH@NO-LOAD(°)	0.8
SENSOR	HALL SENSOR
INSULATION CLASS	CLASS B
INSULATION RESISTANCE	100MΩ MIN @ 500VDC
DIELECTRIC STRENGTH TEST	500VDC for 1 MINUTE
BEARING TYPE	NMB BALL BEARING, C3

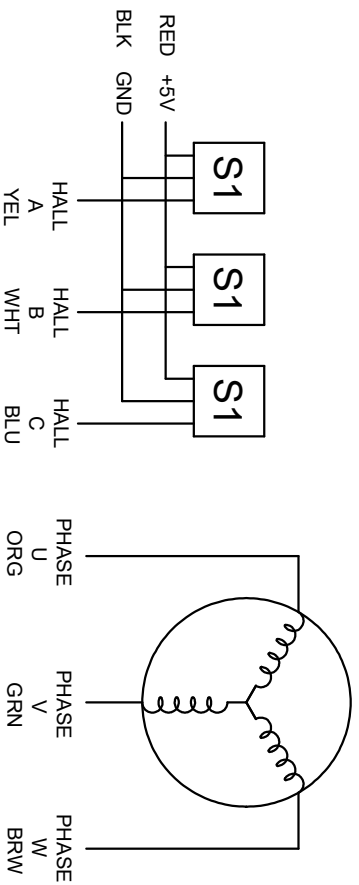

		SCALE		<b>BRUSHLESS DC MOTOR</b> 57BLR70-24-02-HG10
		1.5:1	DRN	
APVD	CHKD	SIGNATURE	DATE	
			12.8.2023	