

SPECIFICATION	VALUE
NO. of PHASES	3
NO. of POLES	4
RATED VOLTAGE(V)	24
RATED CURRENT(A)	5±10%
RATED POWER(W)	84
RATED SPEED w/o GEARBOX(RPM)	3500±10%
RATED TORQUE(N.m)	8.625
GEAR RATIO	50
EFFICIENCY	75.00%REF
MAX.PERMISSIBLE TORQUE(Nm)[lb-in]	20[177.01]
BACKLASH@NO-LOAD(°)	1.6
SENSOR	HALL SENSOR
INSULATION CLASS	CLASS B
INSULATION RESISTANCE	100MΩ MIN @ 500VDC
DIELECTRIC STRENGTH TEST	500VDC for 1 MINUTE
BEARING TYPE	NMB BALL BEARING, C3

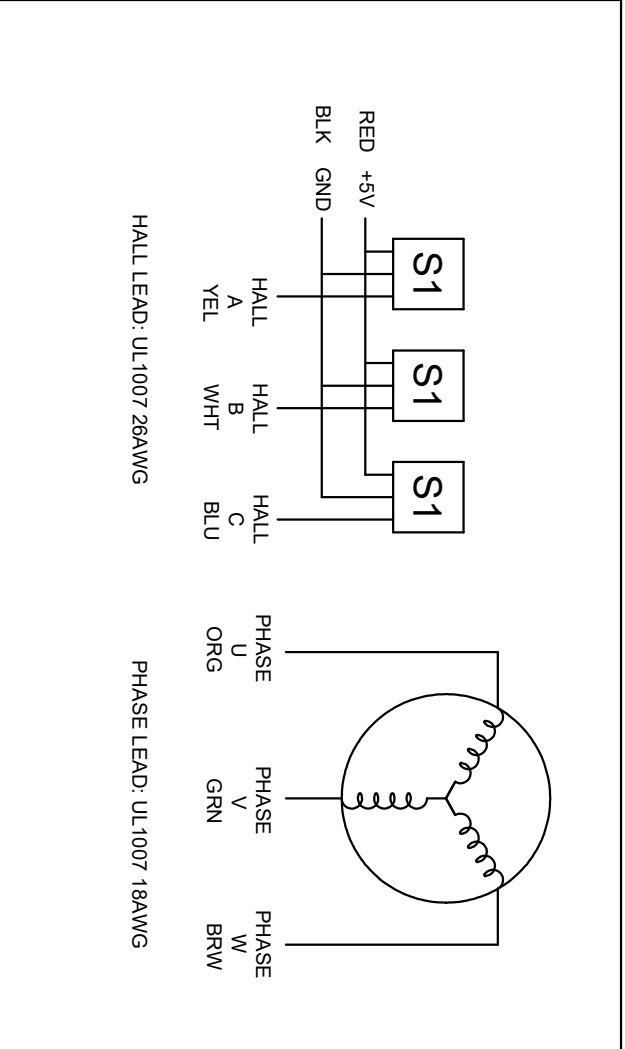

STAPP **IRONLINE**®

SCALE 1.5:1

APVD	
CHKD	
DRN	
SIGNATURE	
DATE	12.8.2023

BRUSHLESS DC MOTOR

57BLR50-24-01-HG50