

END COVER COLOR: BLACK

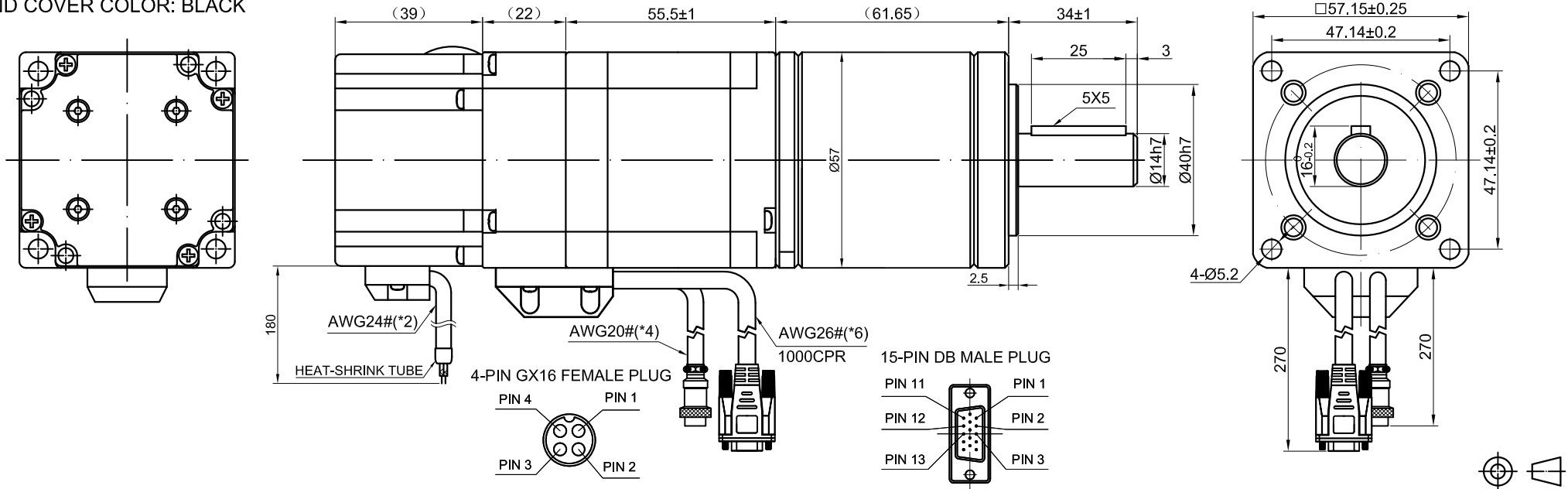

SPECIFICATION	CONNECTION	BIPOLAR
AMPS/PHASE		4.00
RESISTANCE/PHASE(Ohms)@20°C		0.45±10%
INDUCTANCE/PHASE(mH)@1KHz		1.40±20%
HOLDING TORQUE w/o GEARBOX(Nm)[lb-in]		1.20[10.63]
GEAR RATIO		50
EFFICIENCY		75.00%
STEP ANGLE w/o GEARBOX(°)		1.80
BACKLASH@NO-LOAD(°)		1.6
MAX.PERMISSIBLE TORQUE(Nm)		20.00
MOMENT PERMISSIBLE TORQUE(Nm)		40.00
AMBIENT TEMPERATURE(°C)		0 ~ 50
INSULATION CLASS		B
MAX. AXIAL LOAD(N)		100
MAX. RADIAL LOAD(N)		250

TYPE OF CONNECTION (EXTERN)		MOTOR	
PIN NO	BIPOLAR	LEADS	WINDING
1	A+ —	[Diagram showing 4 leads connected to 2 windings]	A+
2	A- —		A-
3	B+ —		B+
4	B- —		B-

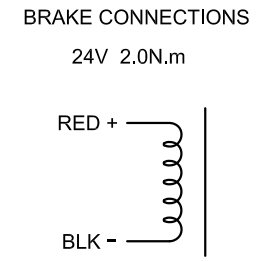

FULL STEP 2 PHASE-Ex. ,  
WHEN FACING MOUNTING END (X)

STEP	A+	B+	A-	B-	CCW	CW
1	+	+	-	-	↓	↑
2	-	+	+	-		
3	-	-	+	+		
4	+	-	-	+		

15-PIN DB MALE PLUG	1	2	3	11	12	13
DESCRIPTION	EA+	VCC	GND	EB+	EB-	EA-



APVD		8.22.2022
CHKD		
SCALE	1:1.5	DRN
SIGNATURE		DATE

**STEPPER MOTOR**  
**23E1KBK20-12-HG50**