

CUSTOMER'S MODEL: NO MODEL
 END COVER COLOR: BLACK

REV.	REVISION RECORD	BY	DATE
0	ORIGIN	ZPJ	7.30.2025

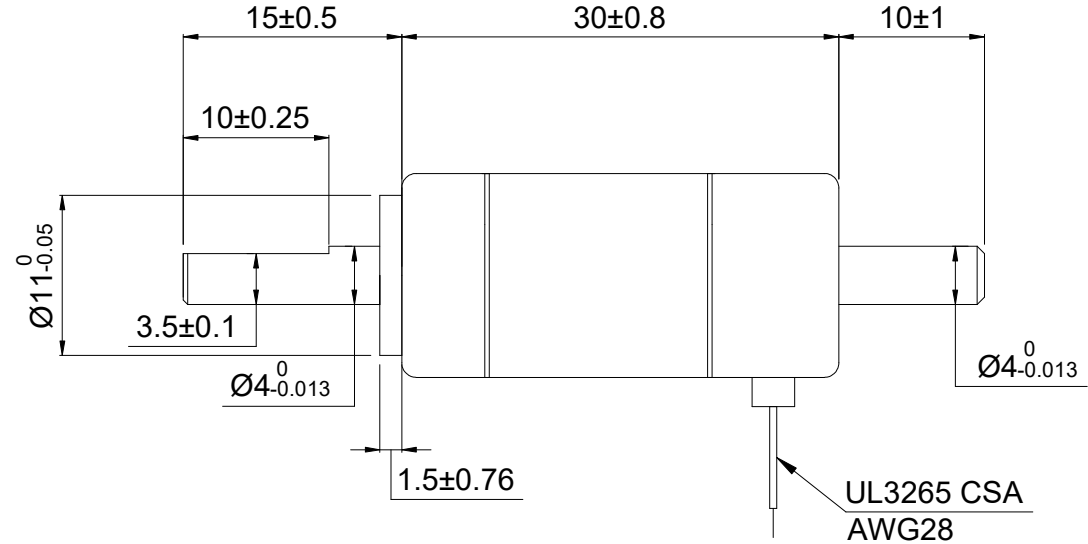
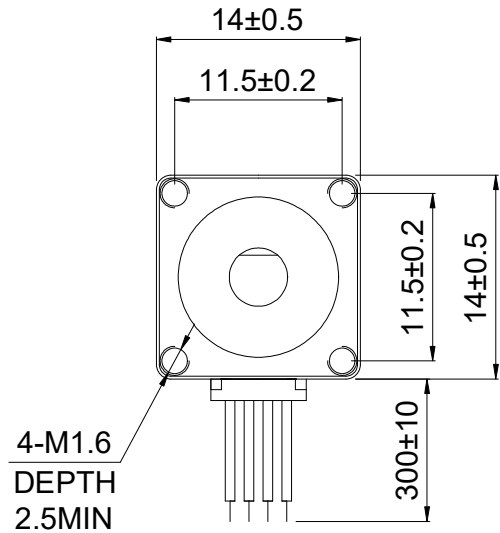

SPECIFICATION	CONNECTION	BIPOLAR
AMPS/PHASE		0.30
RESISTANCE/PHASE(Ohms)@25°C		22.00±10%
INDUCTANCE/PHASE(mH)@1KHz		4.20±20%
HOLDING TORQUE(Nm)[lb-in]		0.0058[0.051]
STEP ANGLE(°)		1.80
STEP ACCURACY(NON-ACCUM)		±5.00%
ROTOR INERTIA(g-cm²)		5.80
WEIGHT(Kg)[lb]		0.03[0.07]
AMBIENT TEMPERATURE		-10°C~50°C[14°F~122°F]
INSULATION CLASS		B 130°C[266°F]
TEMPERATURE RISE		MAX.80°C

COMMENT:
 1.TMBF 6000h OR MORE @ 24V/300RPM
 2.INSULATION RESISTANCE (NORMAL TEMPERATURE AND HUMIDITY): 100 Mohm
 3.DIELECTRIC STRENGTH 500VAC FOR 1MIN.(BETWEEN THE MOTOR COILS AND THE MOTOR CASE)

STEPPER MOTOR
 6HS12-0304D
 S/N: XXXXXXXXXXXXX



MOTOR CONNECTION			
PIN NO	BIPOLAR	LEADS	WINDING
1	A+	BLK	
2	A-	GRN	
3	B+	RED	
4	B-	BLU	

FULL STEP 2 PHASE-Ex.,WHEN FACING MOUNTING END (X)						DIMENSIONS ARE IN MILLIMETERS.	
STEP	A+	B+	A-	B-		DECIMALS	ANGLES
1	+	+	-	-		X ±0.5	±2°
2	-	+	+	-		XX ±0.25	
3	-	-	+	+		XXX ±0.13	
4	+	-	-	+			

STEPPERONLINE®

STEPPER MOTOR

6HS12-0304D

THIS DOCUMENT SHALL NOT BE REPRODUCED NOR SHALL THE INFORMATION CONTAINED HEREIN BE USED BY OR DISCLOSED TO OTHERS UNLESS EXPRESSLY AUTHORIZED IN BY WRITING STEPPERONLINE.

SIGNATURE		DATE
DRN	ZPJ	7.30.2025
APVD	YSX	7.30.2025

REV.	0	SCALE	2:1	DWG NO.	A1683
------	---	-------	-----	---------	-------