

CUSTOMER'S MODEL: NO MODEL
 END COVER COLOR: BLACK

REV.	REVISION RECORD	BY	DATE
0	ORIGIN	MYX	10.30.2025

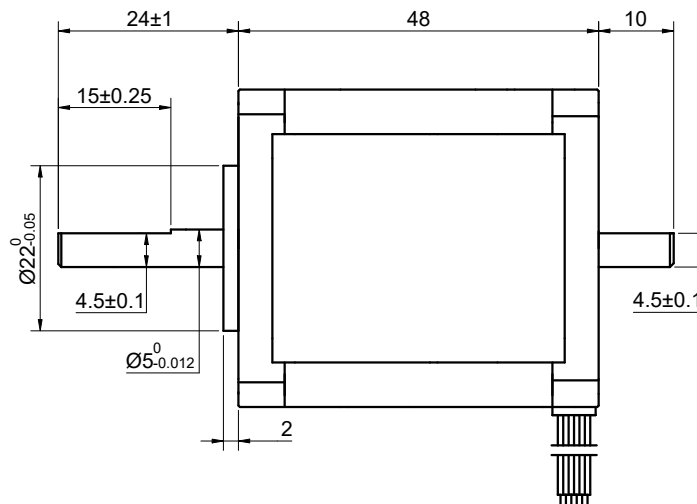

STEPPER MOTOR
 17HM19-0406D
 S/N: XXXXXXXXXXXXX

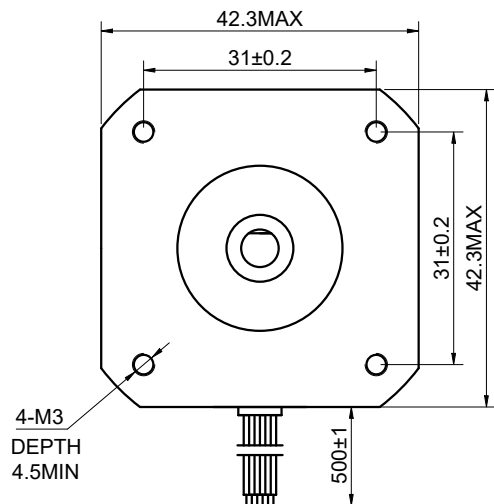

MOTOR CONNECTION			
PIN NO	BIPOLAR	LEADS	WINDING
1	A+	RED	
2	A-	YEL	
3	B+	BLU	
4	B-	GRN	
5	O	BRN	
6	O	ORG	

CONNECTION	UNIPOLAR
SPECIFICATION	
AMPS/PHASE	0.40
RESISTANCE/PHASE(Ohms)@25°C	30.00±10%
INDUCTANCE/PHASE(mH)@1KHz	38.00±20%
HOLDING TORQUE(Nm)[lb-in]	0.32[2.83]
STEP ANGLE(°)	0.90
STEP ACCURACY(NON-ACCUM)	±5.00%
ROTOR INERTIA(g-cm ²)	—
WEIGHT(Kg)[lb]	—
AMBIENT TEMPERATURE	-10°C~50°C[14°F~122°F]
INSULATION CLASS	B 130°C[266°F]
TEMPERATURE RISE	MAX.80°C

COMMENT:
 1.DYNAMIC AXIAL LOAD: 10N MAX
 2.DYNAMIC RADIAL LOAD @ SHAFT LENGTH 20mm: 21N MAX
 3.TMBF 6000h OR MORE @ 24V/300RPM
 4.INSULATION RESISTANCE (NORMAL TEMPERATURE AND HUMIDITY): 100 Mohm
 5.DIELECTRIC STRENGTH 500VAC FOR 1MIN.(BETWEEN THE MOTOR COILS AND THE MOTOR CASE)

FULL STEP 2 PHASE-Ex.,WHEN FACING MOUNTING END (X)							DIMENSIONS ARE IN MILLIMETERS.		
STEP	A+	B+	A-	B-	O(O)		CCW	TOLERANCES AS BELOW:	
1	+	+			+			DECIMALS	
2		+	+		+			X ±0.5	ANGLES
3			+	+	+			X.X ±0.25	±2°
4	+			+	+			X.XX ±0.13	

THIS DOCUMENT SHALL NOT BE REPRODUCED NOR SHALL THE INFORMATION CONTAINED HEREIN BE USED BY OR DISCLOSED TO OTHERS UNLESS EXPRESSLY AUTHORIZED IN BY WRITING STEPPERONLINE.

SIGNATURE		DATE
DRN	MYX	10.30.2025
APVD	LJ	10.30.2025

STEPPERONLINE®

STEPPER MOTOR

17HM19-0406D