

CUSTOMER'S MODEL: NO MODEL
 END COVER COLOR: BLACK

REV.	REVISION RECORD	BY	DATE
0	ORIGIN	MYX	3.9.2026

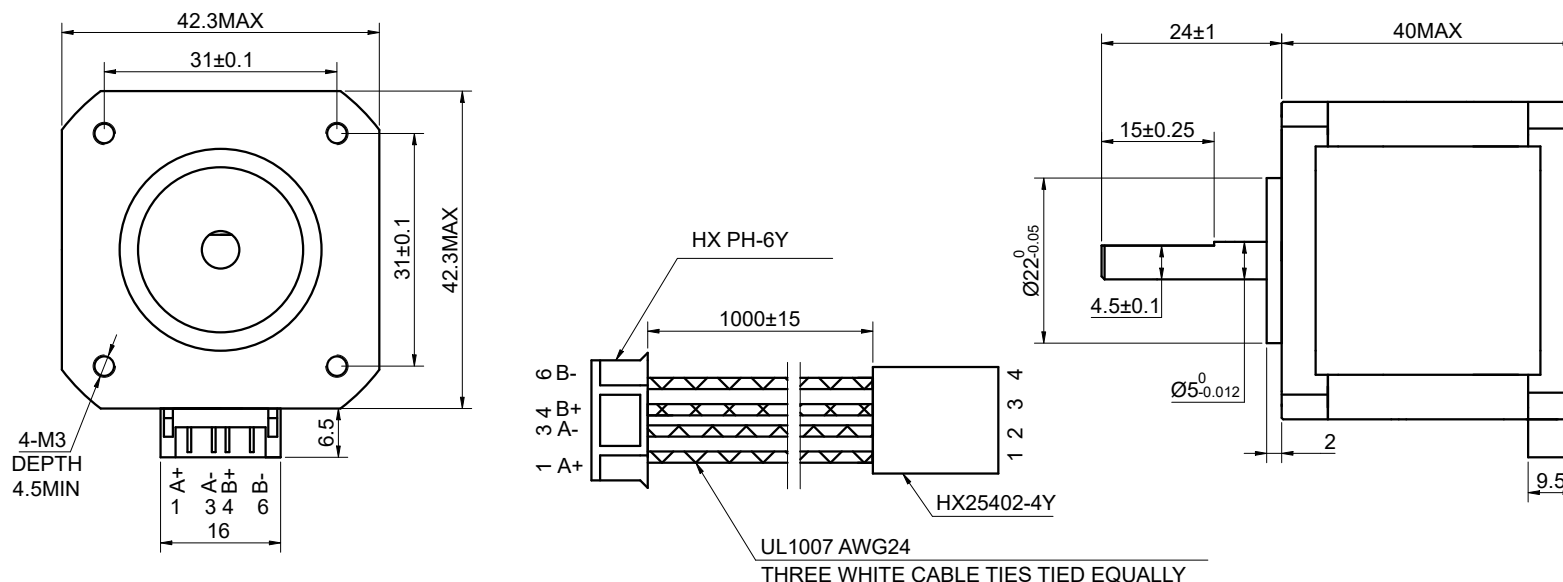

SPECIFICATION	CONNECTION	BIPOLAR
AMPS/PHASE		1.50
RESISTANCE/PHASE(Ohms)@25°C		2.30±10%
INDUCTANCE/PHASE(mH)@1KHz		4.40±20%
HOLDING TORQUE(Nm)[lb-in]		0.45[3.98]
STEP ANGLE(°)		1.80
STEP ACCURACY(NON-ACCUM)		±5.00%
ROTOR INERTIA(g-cm ²)		—
WEIGHT(Kg)[lb]		—
AMBIENT TEMPERATURE		-10°C~50°C[14°F~122°F]
INSULATION CLASS		B 130°C[266°F]
TEMPERATURE RISE		MAX.80°C

COMMENT:
 1.DYNAMIC AXIAL LOAD: 10N MAX
 2.DYNAMIC RADIAL LOAD @ SHAFT LENGTH 20mm: 21N MAX
 3.TMBF 6000h OR MORE @ 24V/300RPM
 4.INSULATION RESISTANCE (NORMAL TEMPERATURE AND HUMIDITY): 100 Mohm
 5.DIELECTRIC STRENGTH 500VAC FOR 1MIN.(BETWEEN THE MOTOR COILS AND THE MOTOR CASE)



MOTOR CONNECTION			
PIN NO	BIPOLAR	LEADS	WINDING
1	A+	BLK	
2	A-	GRN	
3	B+	RED	
4	B-	BLU	

FULL STEP 2 PHASE-Ex.,WHEN FACING MOUNTING END (X)						CCW	CW	THIRD ANGLE PROJECTION
STEP	A+	B+	A-	B-				
1	+	+	-	-				
2	-	+	+	-				
3	-	-	+	+				
4	+	-	-	+				

STEPPERONLINE[®]

STEPPER MOTOR

17HS15-1504S-X1

REV.	0	SCALE	1:1	DWG NO.	A0660
------	---	-------	-----	---------	-------

SIGNATURE		DATE
DRN	MYX	3.9.2026
APVD	LJ	3.9.2026