

REV.	REVISION RECORD	BY	DATE
0	ORIGIN	HW	5.17.2024

CUSTOMER'S MODEL: NO MODEL
 END COVER COLOR: GRAY

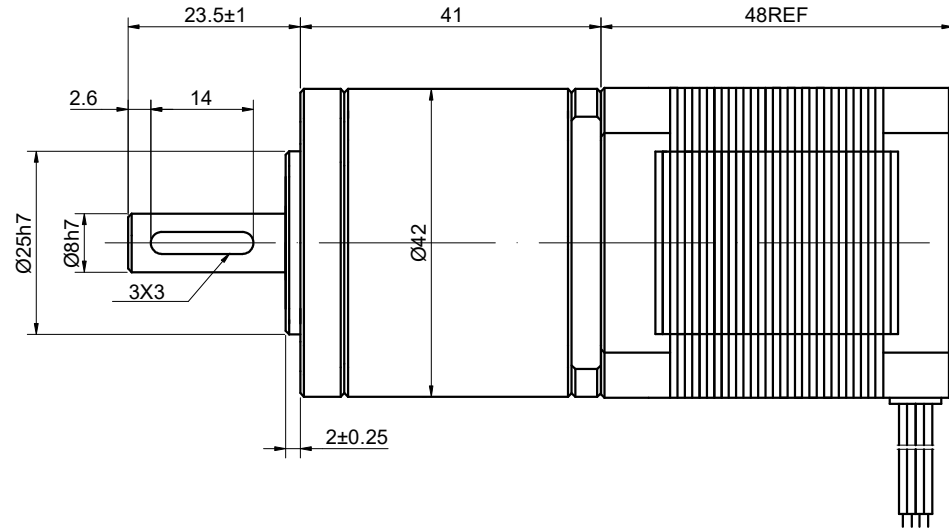
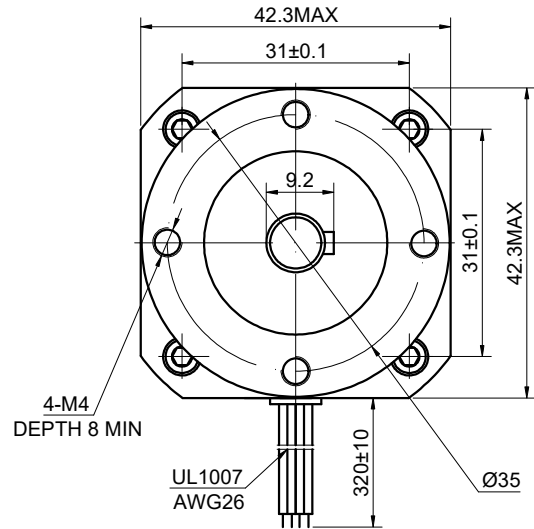

SPECIFICATION	CONNECTION	BIPOLAR
AMPS/PHASE		1.68
RESISTANCE/PHASE(Ohms)@25°C		1.65±10%
INDUCTANCE/PHASE(mH)@1KHz		2.80±20%
HOLDING TORQUE w/o GEARBOX(Nm)[lb-in]		0.44[3.89]
STEP ANGLE w/o GEARBOX(°)		1.80±5.00%
GEAR RATIO		10
MAX.PERMISSIBLE TORQUE(Nm)		3.50
MOMENT PERMISSIBLE TORQUE(Nm)		6.00
EFFICIENCY		92%
BACKLASH@NO-LOAD(arcmin)		<=30
LIFE(h)		6000
AMBIENT TEMPERATURE		-10°C~50°C[14°F~122°F]
INSULATION CLASS		B 130°C[266°F]
TEMPERATURE RISE		MAX.80°C

COMMENT:
 1.DYNAMIC AXIAL LOAD: 50N MAX
 2.DYNAMIC RADIAL LOAD @ SHAFT LENGTH 20mm: 100N MAX
 3.TMBF 6000h OR MORE @ 24V/300RPM
 4.INSULATION RESISTANCE
 (NORMAL TEMPERATURE AND HUMIDITY): 100 Mohm
 5.DIELECTRIC STRENGTH 500VAC FOR 1MIN.(BETWEEN THE MOTOR COILS AND THE MOTOR CASE)

MOTOR CONNECTION(EHR-6)			
PIN NO	BIPOLAR	LEADS	WINDING
1	A+	BLK	
2	A-	GRN	
3	B+	RED	
4	B-	BLU	

FULL STEP 2 PHASE-Ex..WHEN FACING MOUNTING END (X)					DIMENSIONS ARE IN MILLIMETERS.	
STEP	A+	B+	A-	B-	DECIMALS	ANGLES
1	+	+	-	-	X ±0.5	±2°
2	-	+	+	-	X.X ±0.25	
3	-	-	+	+	X.XX ±0.13	
4	+	-	-	+		

STEPPERONLINE®

STEPPER MOTOR

THIS DOCUMENT SHALL NOT BE REPRODUCED NOR SHALL THE INFORMATION CONTAINED HEREIN BE USED BY OR DISCLOSED TO OTHERS UNLESS EXPRESSLY AUTHORIZED IN BY WRITING STEPPERONLINE.

SIGNATURE		DATE
DRN	HW	5.17.2024
APVD	SY	5.20.2024

17HS19-1684S-HG10									
REV.	0	SCALE	1:1	DWG NO.	A0792				