

CUSTOMER'S MODEL: NO MODEL
END COVER COLOR: BLACK

REV.	REVISION RECORD	BY	DATE
0	ORIGIN	ZPJ	7.29.2025

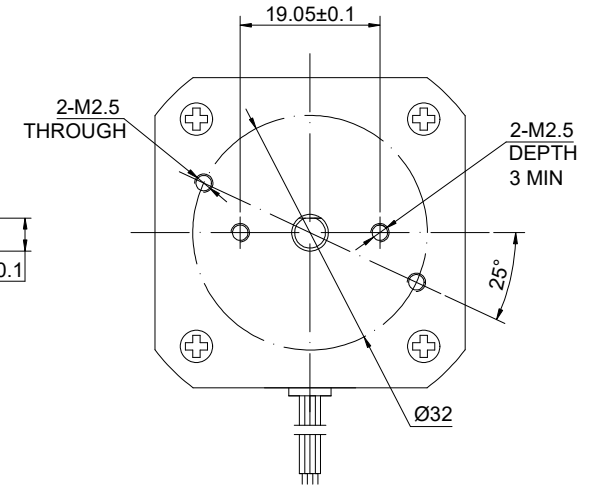
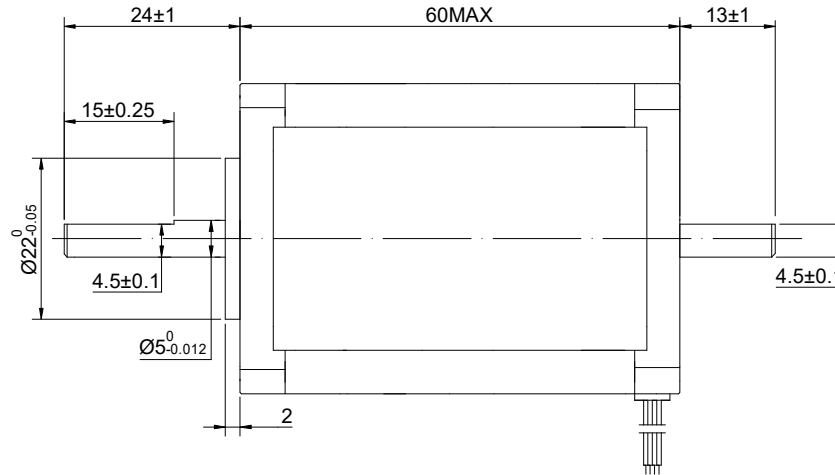
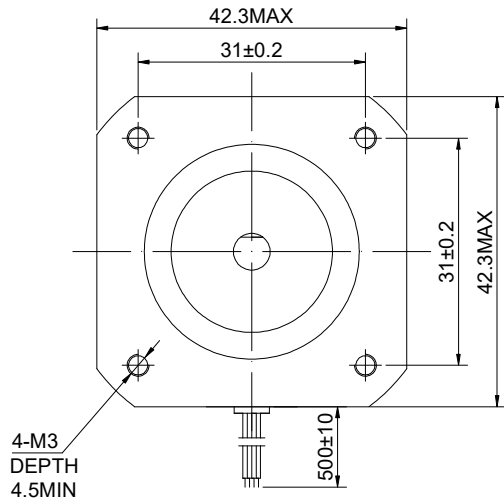

SPECIFICATION	CONNECTION	BIPOLAR
AMPS/PHASE		2.10
RESISTANCE/PHASE(Ohms)@25°C		1.60±10%
INDUCTANCE/PHASE(mH)@1KHz		3.00±20%
HOLDING TORQUE(Nm)[lb-in]		0.65[5.75]
STEP ANGLE(°)		1.80
STEP ACCURACY(NON-ACCUM)		±5.00%
ROTOR INERTIA(g-cm ²)		82.00
WEIGHT(Kg)[lb]		0.50[1.10]
AMBIENT TEMPERATURE		-10°C~50°C[14°F~122°F]
INSULATION CLASS		B 130°C[266°F]
TEMPERATURE RISE		MAX.80°C

COMMENT:
 1.TMBF 6000h OR MORE @ 24V/300RPM
 2.INSULATION RESISTANCE (NORMAL TEMPERATURE AND HUMIDITY): 100 Mohm
 3.DIELECTRIC STRENGTH 500VAC FOR 1MIN.(BETWEEN THE MOTOR COILS AND THE MOTOR CASE)

STEPPER MOTOR
 17HS24-2104D
 S/N: XXXXXXXXXXXXX



MOTOR CONNECTION			
PIN NO	BIPOLAR	LEADS	WINDING
1	A+	BLK	
2	A-	GRN	
3	B+	RED	
4	B-	BLU	

FULL STEP 2 PHASE-Ex.,WHEN FACING MOUNTING END (X)						DIMENSIONS ARE IN MILLIMETERS.	
STEP	A+	B+	A-	B-		CCW	TOLERANCES AS BELOW:
							DECIMALS
1	+	+	-	-			X ±0.5
2	-	+	+	-			X.X ±0.25
3	-	-	+	+			X.XX ±0.13
4	+	-	-	+			

THIS DOCUMENT SHALL NOT BE REPRODUCED NOR SHALL THE INFORMATION CONTAINED HEREIN BE USED BY OR DISCLOSED TO OTHERS UNLESS EXPRESSLY AUTHORIZED IN BY WRITING STEPPERONLINE.

SIGNATURE		DATE
DRN	ZPJ	7.29.2025
APVD	YSX	7.29.2025

STEPPERONLINE®

STEPPER MOTOR

17HS24-2104D

REV.	0	SCALE	1:1	DWG NO.	A0884
------	---	-------	-----	---------	-------