

CUSTOMER'S MODEL: NO MODEL
 END COVER COLOR: GREY

REV.	REVISION RECORD	BY	DATE
0	ORIGIN	LJ	7.31.2025

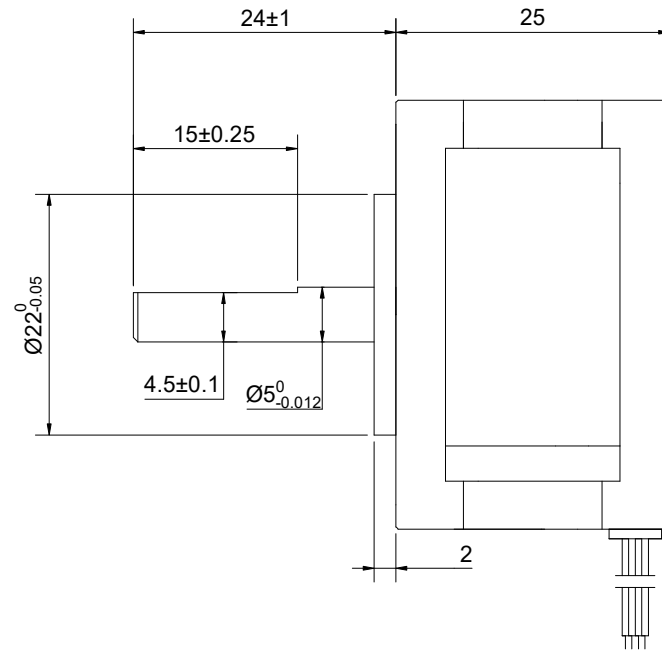
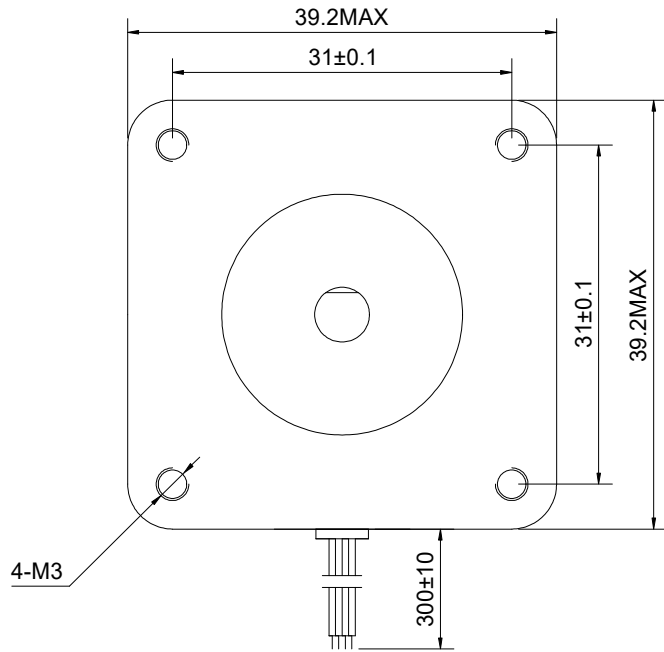

SPECIFICATION	CONNECTION	BIPOLAR
AMPS/PHASE		0.60
RESISTANCE/PHASE(Ohms)@25°C		10.00±10%
INDUCTANCE/PHASE(mH)@1KHz		15.50±20%
HOLDING TORQUE(Nm)[lb-in]		0.16[1.42]
STEP ANGLE(°)		0.90
STEP ACCURACY(NON-ACCUM)		±5.00%
ROTOR INERTIA(g-cm ²)		10
WEIGHT(Kg)[lb]		—
AMBIENT TEMPERATURE		-10°C~50°C[14°F~122°F]
INSULATION CLASS		B 130°C[266°F]
TEMPERATURE RISE		MAX.80°C

COMMENT:
 1.TMBF 6000h OR MORE @ 24V/300RPM
 2.INSULATION RESISTANCE
 (NORMAL TEMPERATURE AND HUMIDITY): 100 Mohm
 3.DIELECTRIC STRENGTH 500VAC FOR 1MIN.(BETWEEN THE MOTOR COILS
 AND THE MOTOR CASE)

STEPPER MOTOR
 16HM10-0604S
 S/N: XXXXXXXXXXXXX



MOTOR CONNECTION			
PIN NO	BIPOLAR	LEADS	WINDING
1	A+	BLK	
2	A-	RED	
3	B+	GRN	
4	B-	BLU	

FULL STEP 2 PHASE-Ex.,WHEN FACING MOUNTING END (X)					CCW	CW	DIMENSIONS ARE IN MILLIMETERS. TOLERANCES AS BELOW: DECIMALS ANGLES X ±0.5 ±2° X.X ±0.25 X.XX ±0.13
STEP	A+	B+	A-	B-			
1	+	+	-	-			
2	-	+	+	-			
3	-	-	+	+			
4	+	-	-	+			

STEPPERONLINE®

STEPPER MOTOR

THIS DOCUMENT SHALL NOT BE REPRODUCED
 NOR SHALL THE INFORMATION CONTAINED
 HEREIN BE USED BY OR DISCLOSED TO
 OTHERS UNLESS EXPRESSLY AUTHORIZED IN
 BY WRITING STEPPERONLINE.

SIGNATURE		DATE
DRN	LJ	7.31.2025
APVD	LDJ	7.31.2025

16HM10-0604S

REV.	0	SCALE	1:1	DWG NO.	A0374
------	---	-------	-----	---------	-------