

| REV. | REVISION RECORD | BY | DATE |
|------|-----------------|-----|----------|
| 0 | ORIGIN | MYX | 4.1.2026 |

CUSTOMER'S MODEL:
END COVER COLOR: BLACK

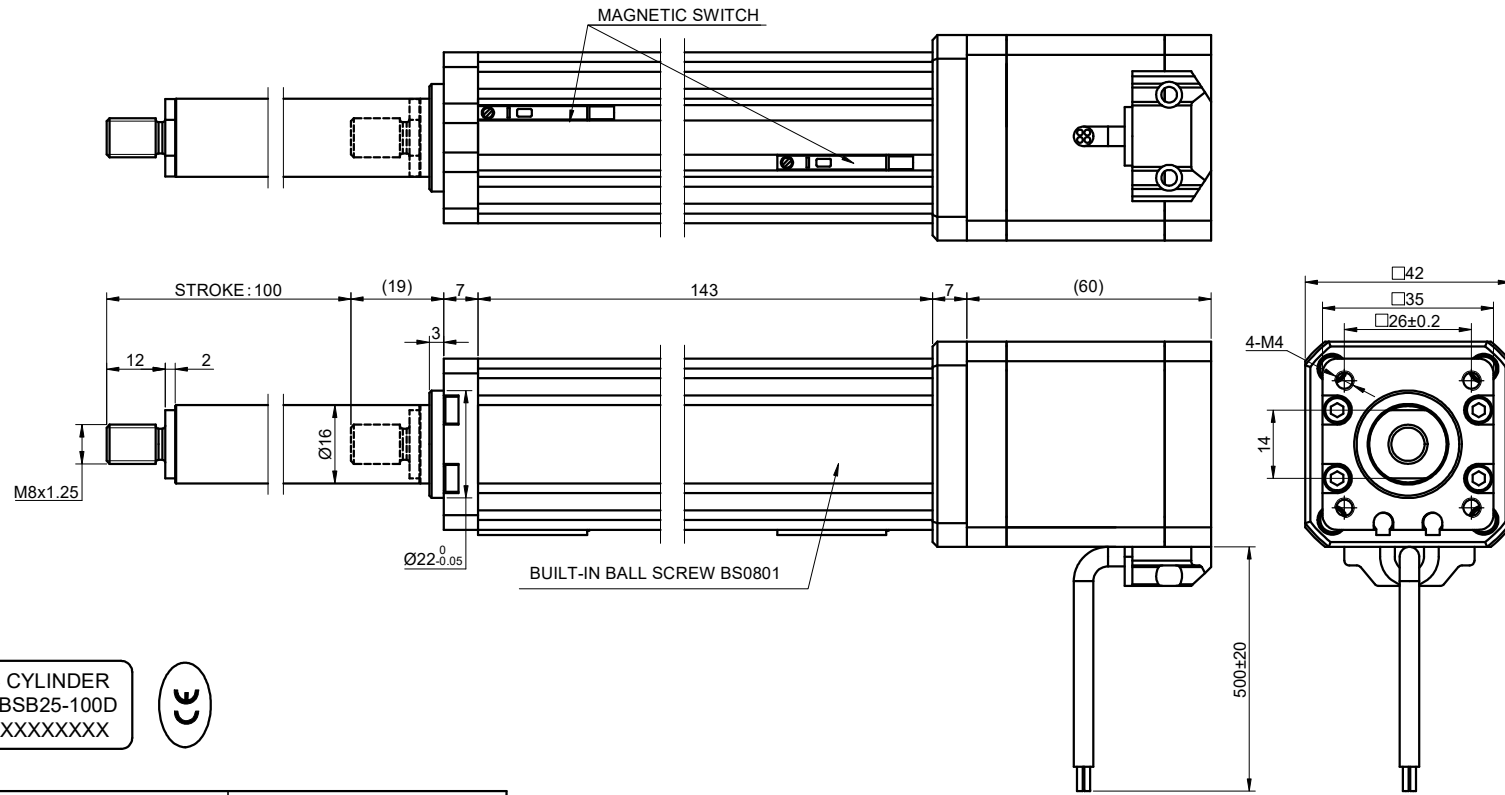

ELECTRIC CYLINDER
LCB17S24BSB25-100D
S/N: XXXXXXXXXXXX



| MAGNETIC SWITCH WIRING | | |
|------------------------|-------------|--------|
| PIN# | DESCRIPTION | COLOUR |
| 1 | DC 5-24V | BROWN |
| 2 | GND | BLUE |
| 3 | SIGNAL | BLACK |

| CONNECTION | BIPOLAR |
|-----------------------------|------------------------|
| SPECIFICATION | |
| AMPS/PHASE | 2.50 |
| RESISTANCE/PHASE(Ohms)@25°C | 0.95±10% |
| INDUCTANCE/PHASE(mH)@1KHz | 2.60±20% |
| HOLDING TORQUE(Nm)[lb-in] | 0.7[6.20] |
| STEP ANGLE(°) | 1.80 |
| STEP ACCURACY(NON-ACCUM) | ±5.00% |
| LEAD(mm) | 1 |
| LINEAR TRAVEL/STEP(mm) | 0.005 |
| AMBIENT TEMPERATURE | -20°C~50°C[-4°F~122°F] |
| INSULATION CLASS | B 130°C[266°F] |
| TEMPERATURE RISE | MAX.80°C |
| AMBIENT HUMIDITY | MAX.85% |

- NOTICE:
1. MOTOR SCREW SHALL NOT BE SUBJECTED TO RADIAL LOAD.
 2. NOT CLAMP OR SQUEEZE THE MOTOR SCREW WITH HARD OBJECTS, SO AS TO AVOID DAMAGING THE THREAD.
 3. MOTOR SCREW IS PRE-COATED WITH SPECIAL GREASE. PLEASE CONTACT THE MANUFACTURER IF RE-GREASING IS REQUIRED.
 4. DO NOT DISASSEMBLE THE MOTOR WITHOUT PERMISSION.
 5. MOTOR MUST BE HANDLED WITH CARE. HOLD THE MOTOR BODY WHEN CARRYING IT; DO NOT LIFT IT BY THE LEAD WIRES.

| MOTOR CONNECTION | | | |
|------------------|---------|---------|---------|
| PIN NO | BIPOLAR | LEADS | WINDING |
| 1 | A+ | RED | |
| 2 | A- | RED/WHT | |
| 3 | B+ | GRN | |
| 4 | B- | GRN/WHT | |

| FULL STEP 2 PHASE-Ex.,WHEN FACING MOUNTING END (X) | | | | | CCW | CW | DIMENSIONS ARE IN MILLIMETERS. TOLERANCES AS BELOW: DECIMALS ANGLES X ±0.5 ±2° X.X ±0.25 X.XX ±0.13 |
|--|----|----|----|----|-----|----|--|
| STEP | A+ | B+ | A- | B- | | | |
| 1 | + | + | - | - | | | |
| 2 | - | + | + | - | | | |
| 3 | - | - | + | + | | | |
| 4 | + | - | - | + | | | |



ELECTRIC CYLINDER

LCB17S24BSB25-100D

THIS DOCUMENT SHALL NOT BE REPRODUCED NOR SHALL THE INFORMATION CONTAINED HEREIN BE USED BY OR DISCLOSED TO OTHERS UNLESS EXPRESSLY AUTHORIZED IN BY WRITING STEPPERONLINE.

| SIGNATURE | | DATE |
|-----------|-----|----------|
| DRN | MYX | 4.1.2026 |
| APVD | ZPJ | 4.8.2026 |