

REV.	REVISION RECORD	BY	DATE
0	ORIGIN	MYX	3.9.2026

CUSTOMER'S MODEL: NO MODEL
 END COVER COLOR: GREY

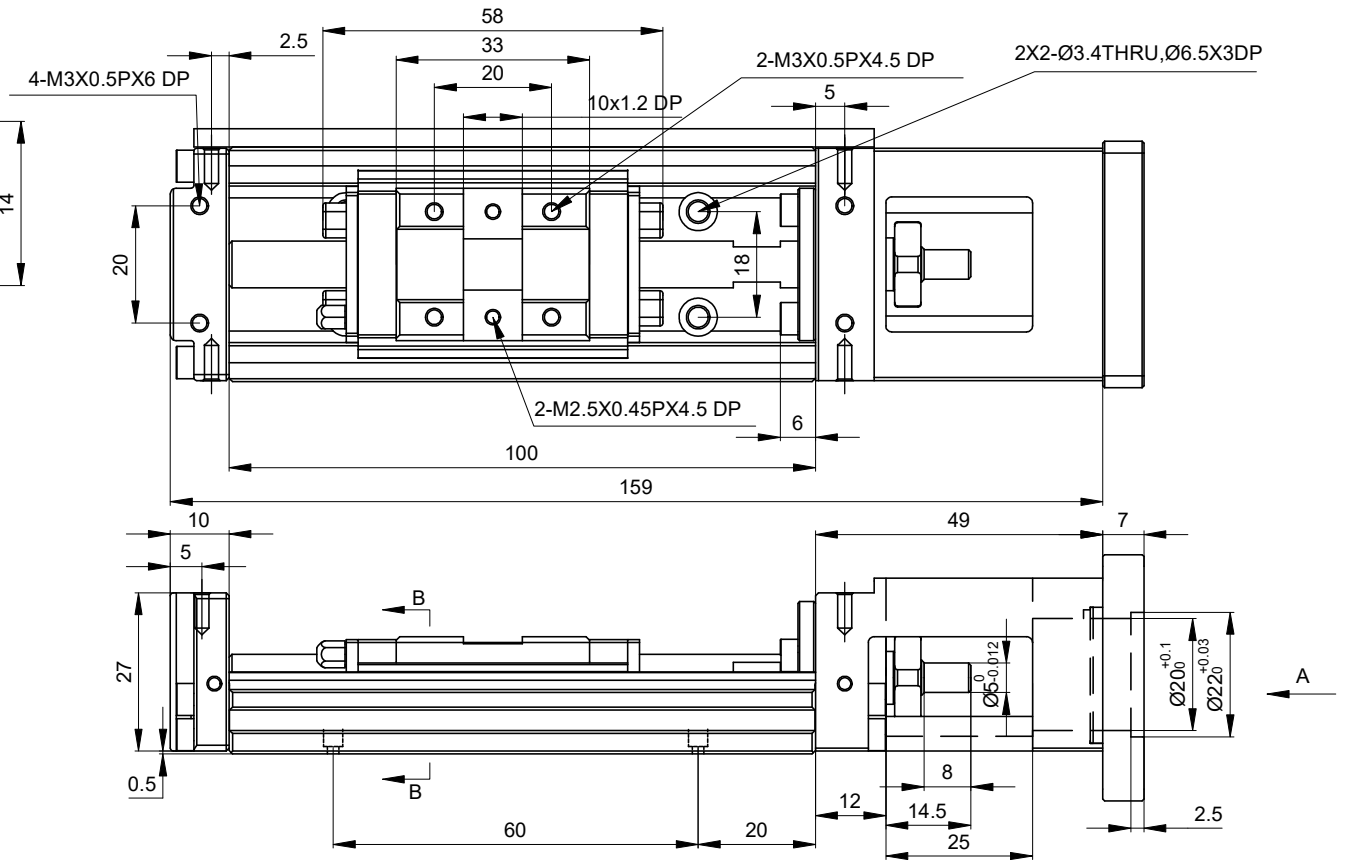
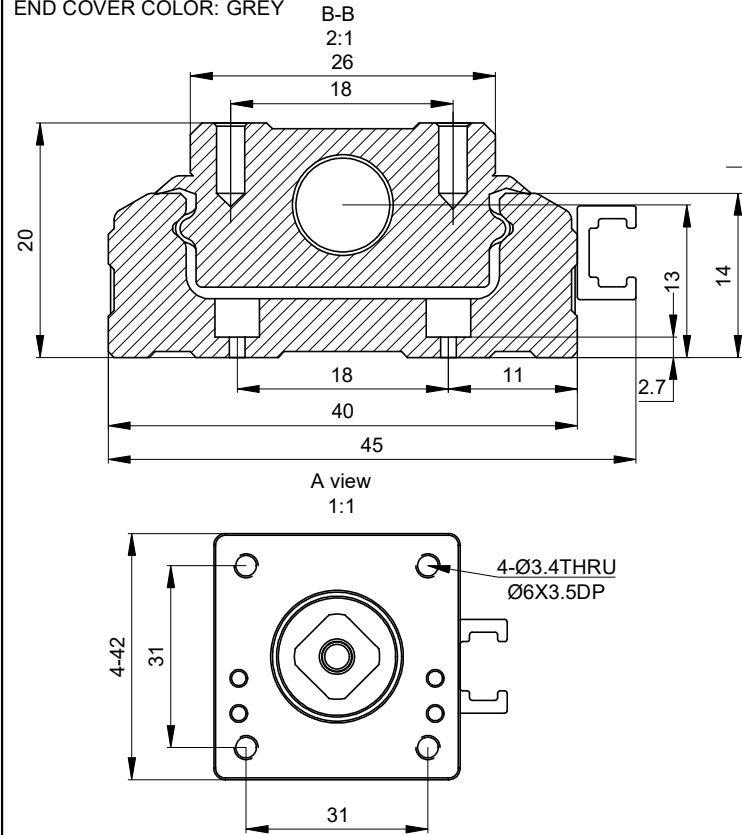

STROKE LENGTH(mm)	36	
POSITION ACCURACY (mm)	±0.003	
BALL SCREW LEAD (mm)	5.00	
MAXIMUM SPEED (mm/s)	500.00	
BALL SCREW	BASIC DYNAMIC RATED LOAD (N)	1374
	BASIC STATIC RATED LOAD (N)	2657
LINEAR GUIDE	BASIC DYNAMIC RATED LOAD (N)	3920
	BASIC STATIC RATED LOAD (N)	6468
BALL SCREW DIAMETER (mm)	C5/Ø8	
ORIGIN SENSOR	--	
INPUT SHAFT LENGTH (mm)	--	
INPUT SHAFT DIAMETER (mm)	--	
WEIGHT(Kg)[lb]	0.48[1.06]	

THIS DOCUMENT SHALL NOT BE REPRODUCED
 NOR SHALL THE INFORMATION CONTAINED
 HEREIN BE USED BY OR DISCLOSED TO OTHERS
 UNLESS EXPRESSLY AUTHORIZED IN BY WRITING
 STEPPERONLINE.

DIMENSIONS ARE IN MILLIMETERS.
 TOLERANCES AS BELOW:
 DECIMALS ANGLES
 X ±0.5 ±°
 X.X ±0.25
 X.XX ±0.13

THIRD ANGLE PROJECTION		⊕
SIGNATURE		DATE
DRN	MYX	3.9.2026
APVD	LJ	3.9.2026

STEPPERONLINE®

STEPPER MOTOR LINEAR ACTUATOR

LK2A40-17DL050-036

REV.	0	SCALE	1:4	DWG NO.	A5940
------	---	-------	-----	---------	-------