

# A6-EC-STO

## Servo Drive

### User Guide

Data code: C2312010XXX

Version: A00

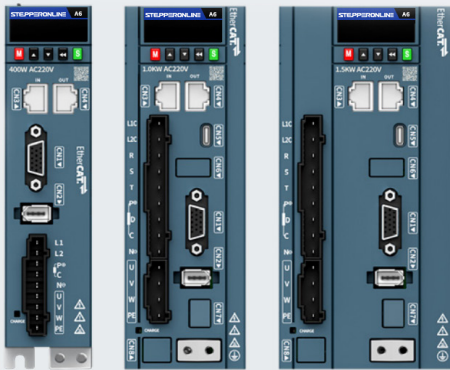

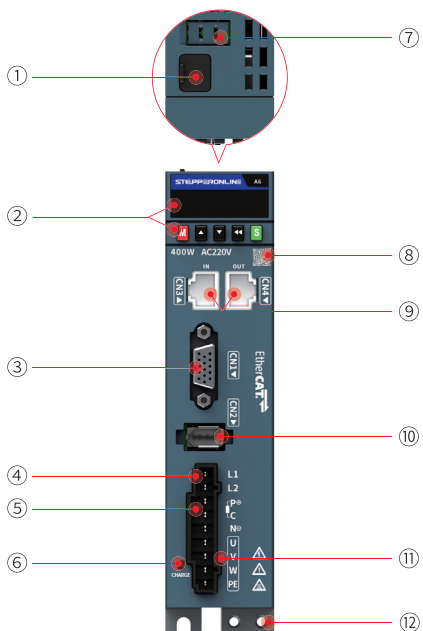

Components of the A6-STO servo drive (SIZE A)

No.	Name	No.	Name
①	Commissioning and communication port (CN6)	⑦	STO terminal port (CN5)
②	Display and operation area	⑧	QR code on machine
③	Control signal port (CN1)	⑨	EtherCAT communication network port (CN3 and CN4)
④	Power input	⑩	Encoder signal port (CN2)
⑤	Braking resistor port	⑪	Motor power output
⑥	Charging indicator	⑫	System ground

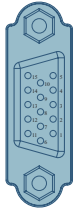

CN1 user control terminal

10	DI1	Positive limit switch
9	DI2	Negative limit switch
8	DI3	Home switch
7	DI4	Probe 2
11	DI5	Probe 1
15	+ 24 V	Internal 24 V power supply Voltage range: 20 V to 28 V Max. output current: 200 mA
14	COM-	(Note: The drive shares a resettable fuse of a 200 mA total current limit with the CN5 Safe Torque Off (STO) function terminal.)
13	COM+	Common terminal of DI terminals
1	DO1+	Servo ready
6	DO1-	
3	DO2+	Fault
2	DO2-	
5	DO3+	Brake
4	DO3-	



CN5 STO function terminals

1	COM	STO reference ground
2	24V	24 V power supply
3	STO1	Control input for STO1
4	STO2	Control input for STO2

## Safety STO Terminal Connection (CN5)

The safety STO terminal (CN5) is used to configure two isolated inputs to dual-channel inputs of the STO function.

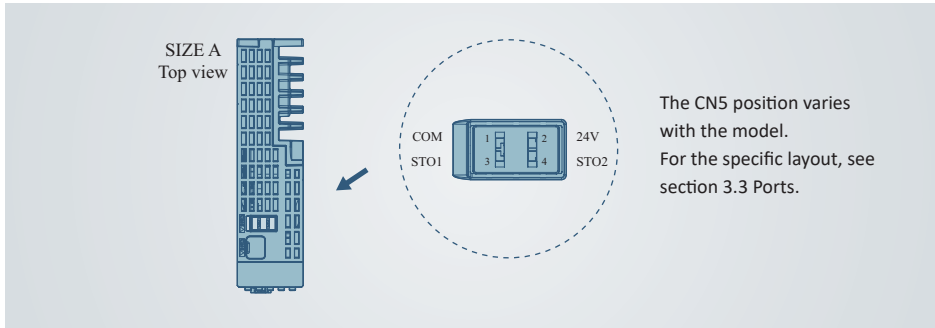

Layout of the safety STO terminal

Pin No	Name	Value	Description
1	COM	0V	STO reference ground
2	24V	24V	24 V power supply
3	STO1	-	Control input for STO1
4	STO2	-	Control input for STO2

### Electrical specifications and connections of input circuit

CN5 input signal features:

- Specifications

The servo drive operates normally only when the input states of STO1 and STO2 are both "High" ("1" or "H").

The servo drive does not operate when either or both the input states of STO1 and STO2 are "Low" ("0" or "L").

- Electrical characteristics of Safety Request Input Signal:

Item	Characteristics	Description
Voltage range	24 VDC ( $\pm 15\%$ )	-
Input current	4 mA (Typ.)	This is the value per channel.
Standards of logic levels	"0" < 3 V, "1" > 15 V	-
Digital input impedance	5.78 k $\Omega$	-

Example connection of external 24 V power supply

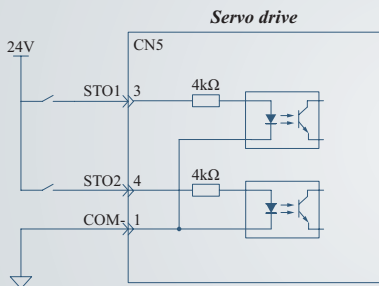

Example connection of internal 24 V power supply

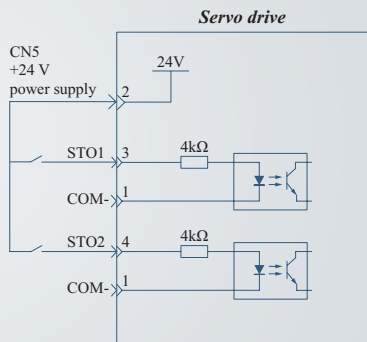

Input circuit connection of the safety STO terminal

## STO Function

### Description:

The Safe Torque Off (STO) function is an optional function for A6-STO series servo drives. It forcibly shuts off the internal drive signals of the servo drives based on safety input signals, to cut off the motor current and prevent unintended motor operation.

STO Function	
Definition	Safe torque off
Description	The STO function makes the machine enter the torque-free state and prevents unintended startup. When the STO function is activated during motor running, the motor gradually comes to a stop.
Safety status	The PWM gate control signal of the servo drive is disabled.
Operation mode	High-demand or continuous mode.

The STO function blocks the PWM signal output to the power layer of the servo drive through terminals STO1 and STO2, to prevent motor running. The two +24 VDC signals must be in an active state to enable normal operation of the servo drive. If either or both of them are set to a low level, the PWM signal will be blocked within the next 30 ms.

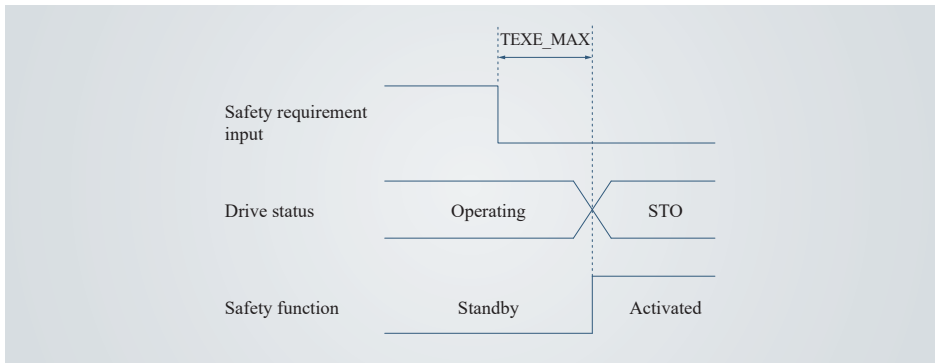

### STO function instruction:

STO1 Input	STO2 Input	PWM Signal
H	H	Enabled
L	H	Disabled
H	L	Disabled
L	L	Disabled

Code	Name	Function Name	Description	Remarks
Functions of output signals				
FunOUT.1	S-RDY	Servo ready	The servo drive is ready to receive the S-ON signal. Active: Servo ready Inactive: Servo not ready	-
FunOUT.2	TGON	Motor rotation signal	Inactive: Absolute value of filtered motor speed lower than the setpoint of C03.2D Active: Absolute value of filtered motor speed reaching the setpoint of C03.2D	-
FunOUT.3	BK	Brake output	Active: Brake signal outputted Inactive: Brake signal not outputted	-
FunOUT.5	WARN	Alarm	Active: Warning occurred on the servo drive Inactive: No warning occurred on the servo drive or the warning has been reset	-
FunOUT.4	ALM	Fault	Active: Fault occurred on the servo drive Inactive: No fault occurred on the servo drive or the fault has been reset	-
FunOUT.18	EDM	EDM output	Active: STO function triggered Inactive: STO function not triggered	The EDM outputs active signals only when the 24 V input voltages for STO1 and STO2 are both disconnected.





Fault Group	Fault Code	Fault Name	Fault Code (203F)	Bus Fault Code (603F)	Resettable
Class 1	Er48.0	STO status exception	0x480	0x0480	Resettable
	Er48.1	STO buffer 5 V power fault	0x481	0x0481	Resettable
	Er48.2	Optocoupler fault in STO pulse detection	0x482	0x0482	Resettable
	Er48.3	STO buffer detection failure	0x483	0x0483	Resettable

## 60FDh: DI status

- Indicates current DI logic of the drive. 0: Inactive; 1: Active

Bit	Description
0	Reverse overtravel active
1	Forward overtravel active
2	Home signal active
3 to 15	N/A
16	DI1 input active
17	DI2 input active
18	DI3 input active
19	DI4 input active
20	DI5 input active
21 to 26	NA
27	STO1 signal input
28	STO2 signal input
29	EDM output active

## Status display

LED Display	Meaning	Description
	① Display of the model with brake	On: Model with brake Off: Model without brake
	② Status of the network port	No display: No network port is connected. " — " displayed: The OUT network port is connected. " _ " displayed: The IN network port is connected.
	③ Communication status	PROFINET state machine status of the slave. 1: Initializing 2: Pre-operation 3: Synchronizing 4: Running
	④ Running mode	Current operating mode of the servo 1: AC1 (Open-loop velocity control) 3: AC3 (Servo internal position control) 4: AC4 (PLC internal position control + Servo velocity control) 5: DSC (Dynamic servo control)
	⑤ Servo status	nr: Servo not ready  sto: Safe torque off (STO)  rd: Servo ready  rn: Servo running 