

CUSTOMER'S MODEL: NO MODEL  
 END COVER COLOR: BLACK

REV.	REVISION RECORD	BY	DATE
0	ORIGIN	LDJ	8.13.2025

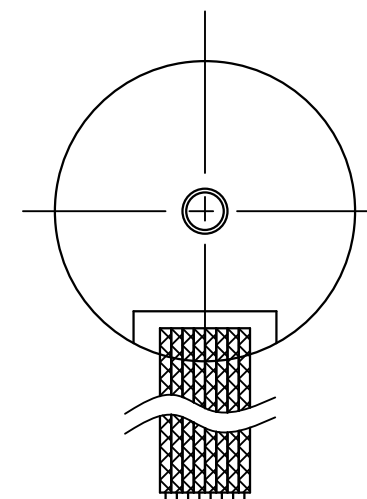
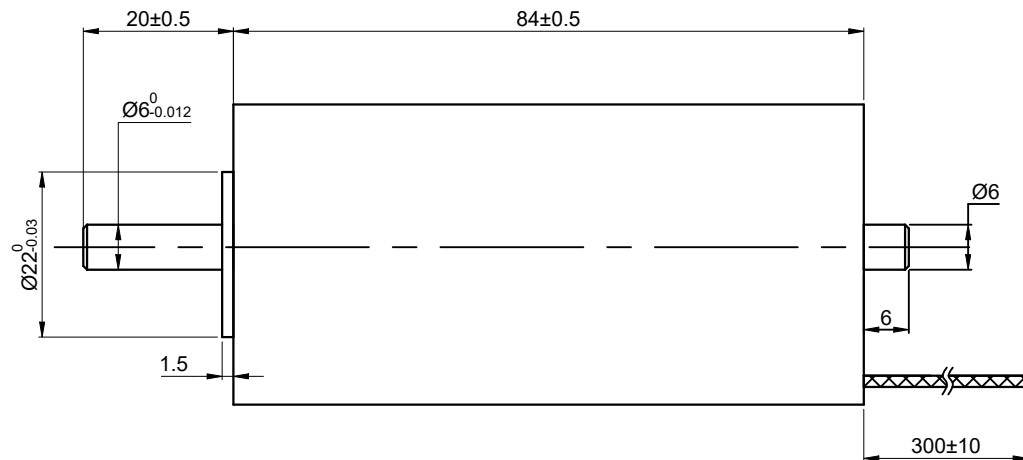
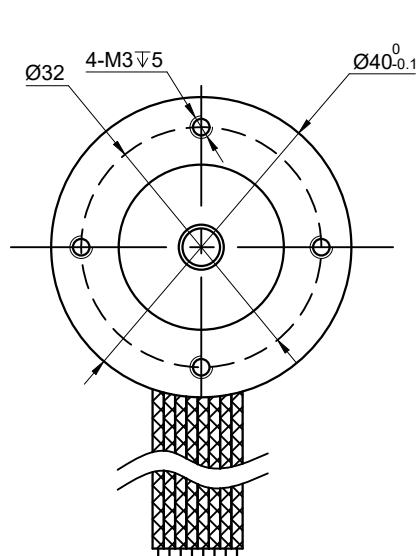

SPECIFICATION	VALUE
RATED VOLTAGE(V)	310
TERMINAL RESISTANCE(Ohms)	1.8
TERMINAL INDUCTANCE(mH)	0.48
NO LOAD SPEED(RPM)	15000
NO LOAD CURRENT(A)	0.7
RATED SPEED(RPM)	11000
RATED CURRENT(A)	1.32
RATED TORQUE(mNm)	260
RATED POWER(W)	299.48
THE GREATEST POWER OUTPUT(W)	13238.94
EFFICIENCY(%)	87.66
TORQUE CONSTANT (mNm/A)	196.55
STALL TORQUE (mNm)	33712.69
BACK-EMF CONSTANT (mV/RPM)	20.58
SPEED CONSTANT (RPM/V)	48.58
FRICTION TORQUE (mNm)	137.58
CURRENT CONSTANT (A/mNm)	0.01

1. OPERATING TEMPERATURE RANGE:  
 -20°C~80°C[-4°F~176°F]

2. WIN ING MAX PERMISSIBLE:  
 180°C[356°F]

3. NO. of POLES: 2

THIS DOCUMENT SHALL NOT BE REPRODUCED NOR SHALL THE INFORMATION CONTAINED HEREIN BE USED BY OR DISCLOSED TO OTHERS UNLESS EXPRESSLY AUTHORIZED IN BY WRITING STEPPERONLINE.

DIMENSIONS ARE IN MILLIMETERS.  
 TOLERANCES AS BELOW:  
 DECIMALS ANGLES  
 X ±0.5 ±2°  
 X.X ±0.25  
 X.XX ±0.13

THIRD ANGLE PROJECTION

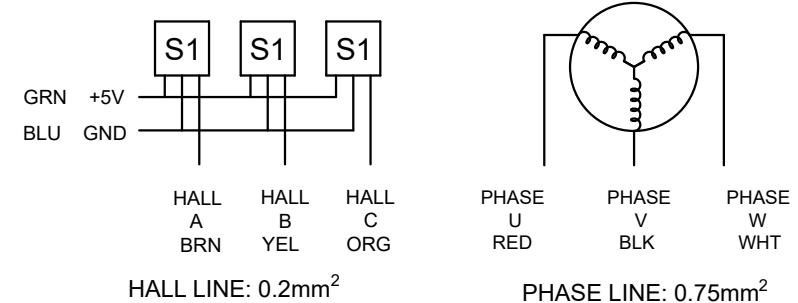

**STEPPERONLINE®**

**BRUSHLESS DC MOTOR**

**40CL84-310-P2-11000**

REV.	0	SCALE	1:1	DWG NO.	A4898
------	---	-------	-----	---------	-------

SIGNATURE		DATE
DRN	LDJ	8.13.2025
APVD	MYX	8.13.2025