

REV.	REVISION RECORD	BY	DATE
0	ORIGIN	MYX	8.12.2025

CUSTOMER'S MODEL: NO MODEL
 END COVER COLOR: BLACK

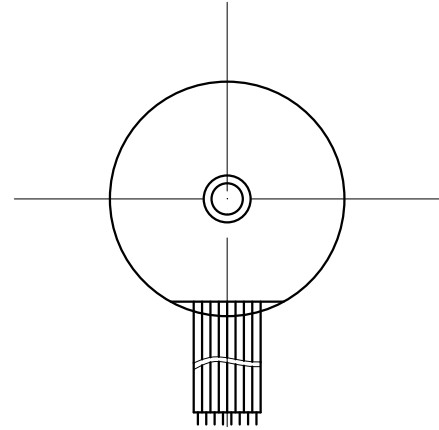
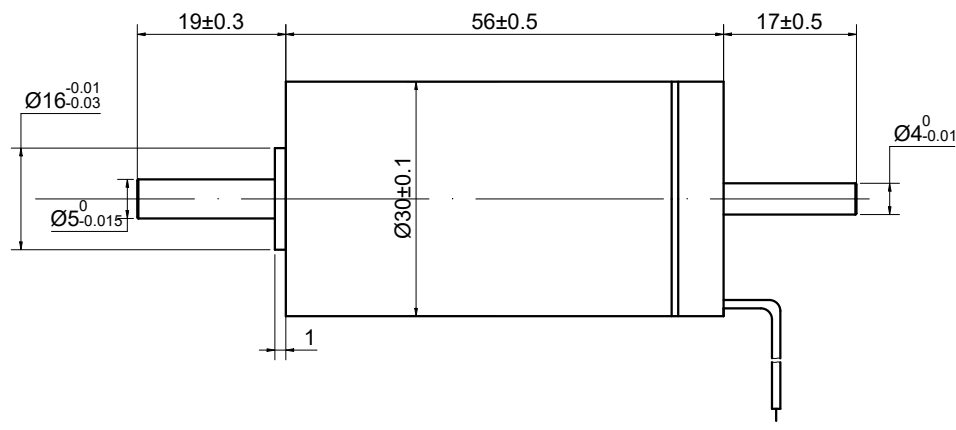
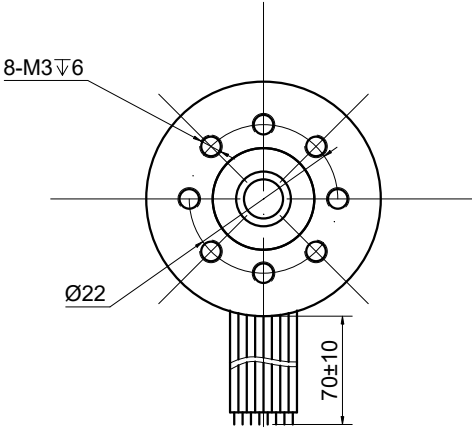

SPECIFICATION	VALUE
RATED VOLTAGE(V)	24
TERMINAL RESISTANCE(Ohms)	2.69
TERMINAL INDUCTANCE(mH)	0.3
NO LOAD SPEED(RPM)	8000
NO LOAD CURRENT(A)	0.2
RATED SPEED(RPM)	4820
RATED CURRENT(A)	1.61
RATED TORQUE(mNm)	45
RATED POWER(W)	22.71
THE GREATEST POWER OUTPUT(W)	51.16
EFFICIENCY(%)	72.30
TORQUE CONSTANT (mNm/A)	28.01
STALL TORQUE (mNm)	244.26
BACK-EMF CONSTANT (mV/RPM)	2.93
SPEED CONSTANT (RPM/V)	340.98
FRICTION TORQUE(mNm)	5.60
CURRENT CONSTANT (A/mNm)	0.04

1. OPERATING TEMPERATURE RANGE:
 -20°C~80°C[-4°F~176°F]
 2. WINDING MAX PERMISSIBLE:
 180°C[356°F]
 3. NO. of POLES: 2

DIMENSIONS ARE IN MILLIMETERS.
 TOLERANCES AS BELOW:
 DECIMALS ANGLES
 X ±0.5 ±2°
 X.X ±0.25
 X.XX ±0.13

THIRD ANGLE PROJECTION

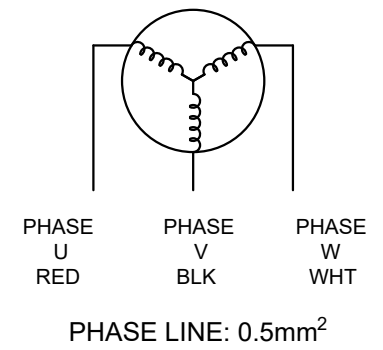
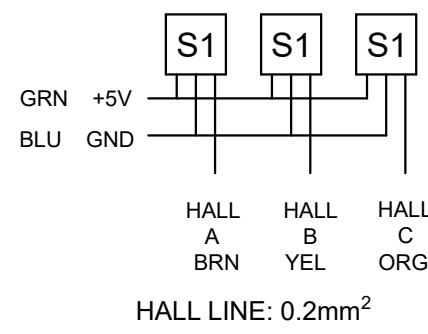

STEPPERONLINE®

BRUSHLESS DC MOTOR

30CL56-24-P2-4820

REV.	0	SCALE	1:1	DWG NO.	A4864
------	---	-------	-----	---------	-------

THIS DOCUMENT SHALL NOT BE REPRODUCED NOR SHALL THE INFORMATION CONTAINED HEREIN BE USED BY OR DISCLOSED TO OTHERS UNLESS EXPRESSLY AUTHORIZED IN BY WRITING STEPPERONLINE.		SIGNATURE	DATE
DRN	MYX	8.12.2025	
APVD	LDJ	8.13.2025	