

REV.	REVISION RECORD	BY	DATE
0	ORIGIN	MYX	8.12.2025

CUSTOMER'S MODEL: NO MODEL
 END COVER COLOR: BLACK

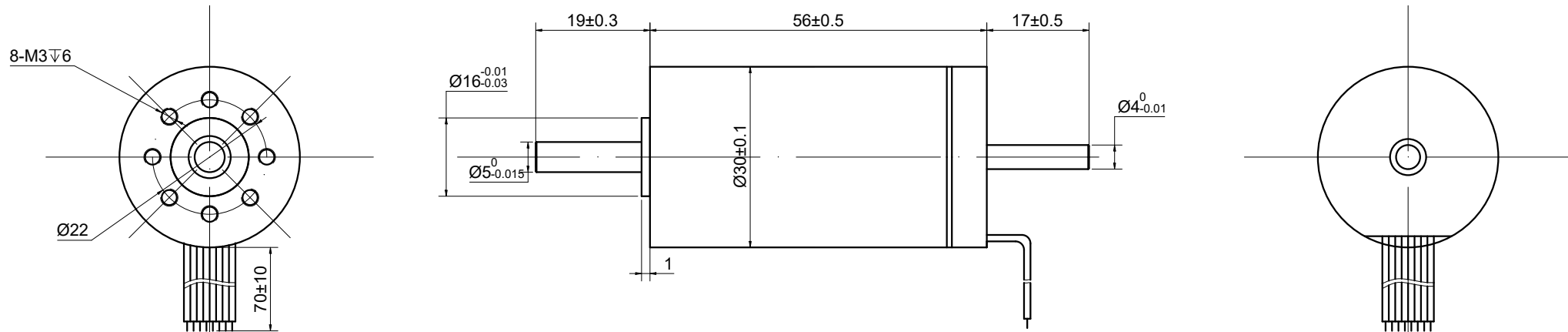

SPECIFICATION	VALUE
RATED VOLTAGE(V)	24
TERMINAL RESISTANCE(Ohms)	1.12
TERMINAL INDUCTANCE(mH)	0.13
NO LOAD SPEED(RPM)	19500
NO LOAD CURRENT(A)	0.4
RATED SPEED(RPM)	15500
RATED CURRENT(A)	3.9
RATED TORQUE(mNm)	45
RATED POWER(W)	73.04
THE GREATEST POWER OUTPUT(W)	123.82
EFFICIENCY(%)	74.54
TORQUE CONSTANT (mNm/A)	11.53
STALL TORQUE (mNm)	242.53
BACK-EMF CONSTANT (mV/RPM)	1.21
SPEED CONSTANT (RPM/V)	827.96
FRICTION TORQUE (mNm)	4.61
CURRENT CONSTANT (A/mNm)	0.09

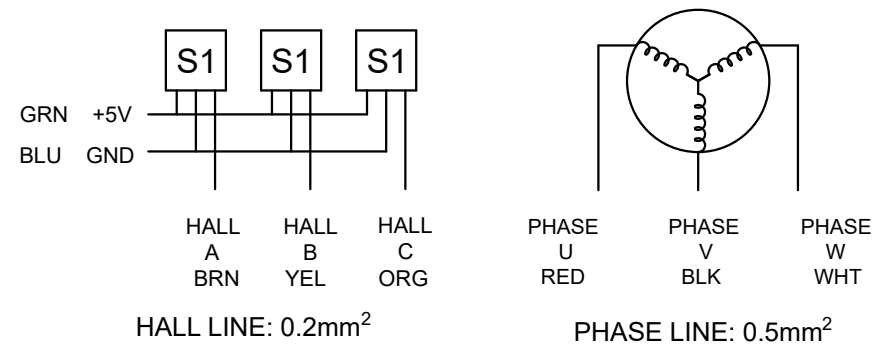

1. OPERATING TEMPERATURE RANGE:
 -20°C~80°C[-4°F~176°F]

2. WIN ING MAX PERMISSIBLE:
 180°C[356°F]

3. NO. of POLES: 2

THIS DOCUMENT SHALL NOT BE REPRODUCED NOR SHALL THE INFORMATION CONTAINED HEREIN BE USED BY OR DISCLOSED TO OTHERS UNLESS EXPRESSLY AUTHORIZED IN BY WRITING STEPPERONLINE.

DIMENSIONS ARE IN MILLIMETERS.
 TOLERANCES AS BELOW:
 DECIMALS ANGLES
 X ±0.5 ±2°
 X.X ±0.25
 X.XX ±0.13

THIRD ANGLE PROJECTION

SIGNATURE DATE

DRN MYX 8.12.2025

APVD LDJ 8.13.2025

STEPPERONLINE®

BRUSHLESS DC MOTOR

30CL56-24-P2-15500

REV.	0	SCALE	1:1	DWG NO.	A4863
------	---	-------	-----	---------	-------