

# STEPPERONLINE®

User Manual

## DM556PR

Bus stepper driver instruction manual

Version: V1.0

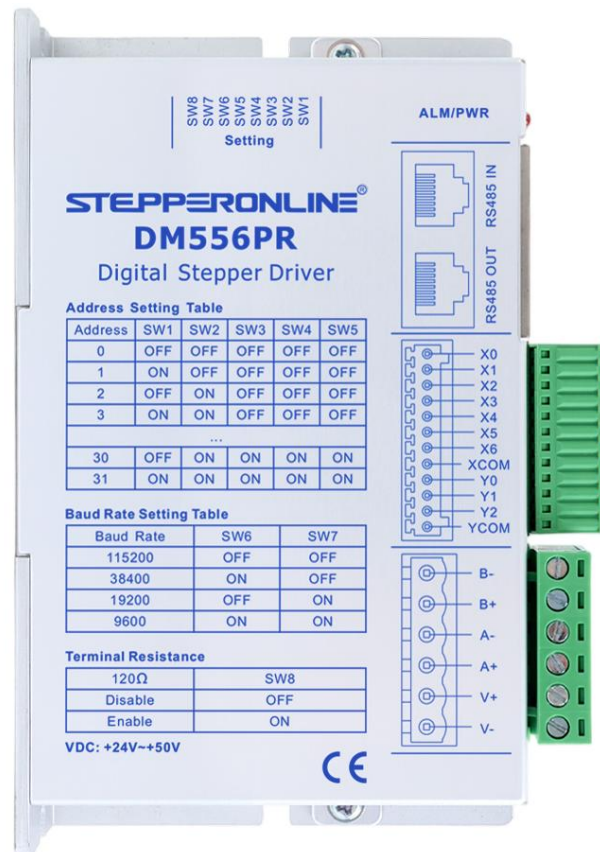

©2025 All Rights Reserved

Address: 15-4, #799 Hushan Road, Jiangning, Nanjing, China

Tel: 0086-2587156578

Web: [www.omc-stepperonline.com](http://www.omc-stepperonline.com)

Sales: [sales@stepperonline.com](mailto:sales@stepperonline.com)

Support: [technical@stepperonline.com](mailto:technical@stepperonline.com)

# Catalogue

Revision history .....	1
Introduction .....	2
Chapter 1 Overview .....	3
1.1 Product introduction .....	3
1.2 Peculiarity .....	3
1.3 Application field .....	4
Chapter 2 Performance Indicators .....	5
2.1 Electrical characteristic .....	5
2.2 Using environment .....	5
Chapter 3 Installation .....	6
3.1 Mounting dimension .....	6
3.2 Installation Methods .....	6
Chapter 4 Driver Ports and Wiring .....	7
4.1 Wiring diagram .....	7
4.2 Port Definition .....	8
4.2.1 Status light .....	8
4.2.2 MODBUS communication port .....	8
4.2.3 Control signal input/output port .....	9
4.2.4 Power input/motor output port .....	9
4.3 Dial setting .....	10
4.3.1 Communication baud rate setting .....	10
4.3.2 Terminal resistance setting .....	10
4.3.3 Terminal resistance setting .....	11
4.4 Input/output port operation .....	12
Chapter 5 Driver Status Indicators .....	13
Chapter 6 General Troubleshooting methods .....	14

## Revision history

Version	Description	Date	Remark
V1.0	First edition release	2025.04.15	

## Introduction

Thank you for using this stepper drive.

Before using this product, be sure to read this manual carefully to understand the necessary safety information, precautions, and operation methods.

The wrong operation can lead to extremely serious consequences.

## Statement

The design and manufacture of this product does not have the ability to protect personal safety from the threat of mechanical systems. Users are requested to consider safety protection measures during the design and manufacture of mechanical systems to prevent accidents caused by improper operation or abnormal products.

Due to product improvements, the contents of the manual are subject to change without notice.

Our company will not be responsible for any modification of the product by the user.

When reading, please note the following marks in the manual:



Remind you to pay attention to the main points in the text.



Indicates that improper operations may result in personal injury or equipment damage.

## Chapter 1 Overview

### 1.1 Product introduction

DM556PR bus stepper motor driver is based on the traditional digital open loop stepper driver to increase the bus communication and single-axis controller function. The bus communication adopts RS-485 interface, and the protocol supports the standard MODBUS-RTU protocol.

### 1.2 Peculiarity

- New generation 32-bit DSP technology, high cost performance, good stability, low noise, low vibration.
- Bus communication using RS485 bus communication interface, support standard MODBUS-RTU protocol, users can simultaneously control up to 31 drivers.
- Has a wealth of input and output interfaces, used to complete position control, speed control, return to the origin and other single-axis motion control functions.
- The user can set the current, subdivision and lock the current size through the bus; Control motor start and stop and query the real-time state of motor operation.
- Supports four motion control function modes: CSP, PP, PV and HOME.
- 3 photoelectric isolation high-speed differential output interface, can control the start and stop of the motor through external signals
- 7 photoelectric isolation single-end input interfaces to receive external control signals to enable the driver to start, stop, and emergency stop
- Three photoelectric isolation output ports to output driver status and control signals.
- Subdivision 400-51200 arbitrary adjustable, smooth and accurate current control, motor heating is small.
- The drive current RMS is adjustable below 4.0A.
- Voltage range: DC24-50V.
- Has over voltage, under voltage, over current and other protection functions.

## **1.3 Application field**

This product is suitable for a variety of small and medium automation equipment and instrument applications. For example: stripper, marking machine, cutting machine, plotter, CNC machine tool, automatic assembly equipment, etc.

## Chapter 2 Performance Indicators

### 2.1 Electrical characteristic

Argument	DM556PR			
	Minimum value	Typical value	Maximum value	Unit
Continuous output current	0	2.0	4.0	A
Input supply voltage	24	24	50	Vdc
Logic input current	7.0	10	16	mA
Logic input voltage	5	-	24	V
Insulation resistance	100	-	-	MΩ

### 2.2 Using environment

Cooling mode	Natural cooling	
Use environment	Use occasion	Try to stay away from other heating equipment, avoid dust, oil mist, corrosive gas, strong vibration places, flammable gas and conductive dust are prohibited
	Temperature	0°C~50°C
	Humidity	40-90%RH (non-condensation)
	Vibration	10~55Hz/0.15mm
Storage temperature	-20°C~+70°C	

# Chapter 3 Installation

## 3.1 Mounting dimension

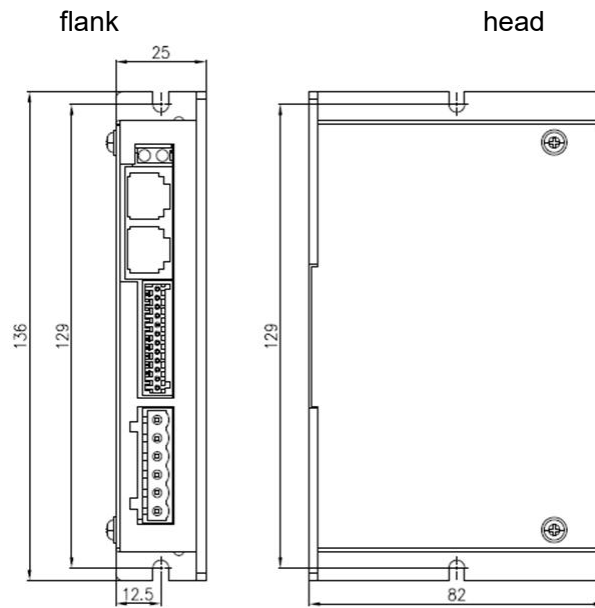

Mounting dimension drawing (unit: mm)

## 3.2 Installation Methods

When installing the driver, please use the upright side installation to form strong air convection on the driver surface; If necessary, install a fan close to the driver to force the heat to dissipate to ensure that the driver works within the reliable operating temperature range (the reliable operating temperature of the driver is usually within 50°C, and the operating temperature of the motor is within 80°C).

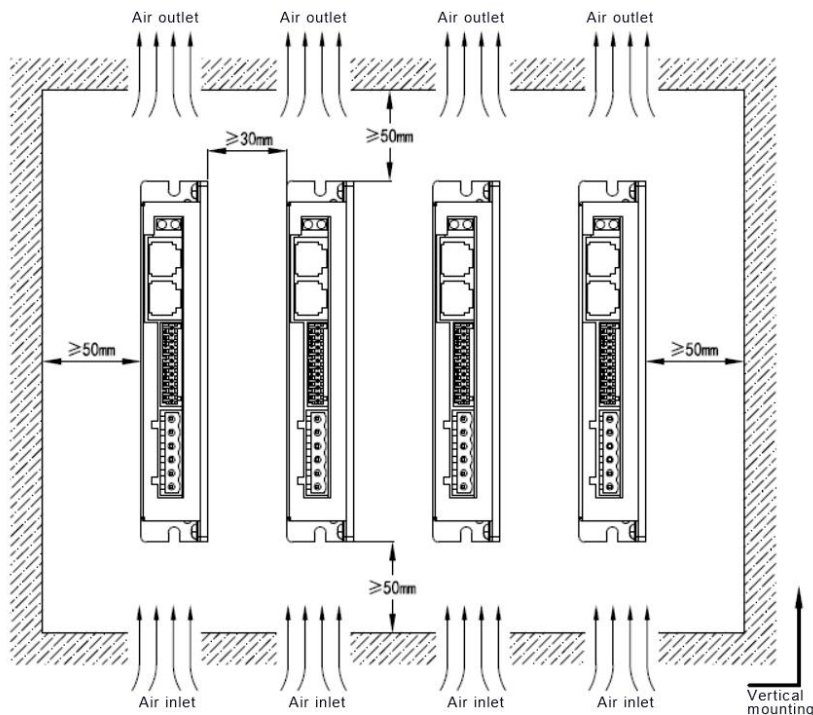

## Chapter 4 Driver Ports and Wiring

### 4.1 Wiring diagram

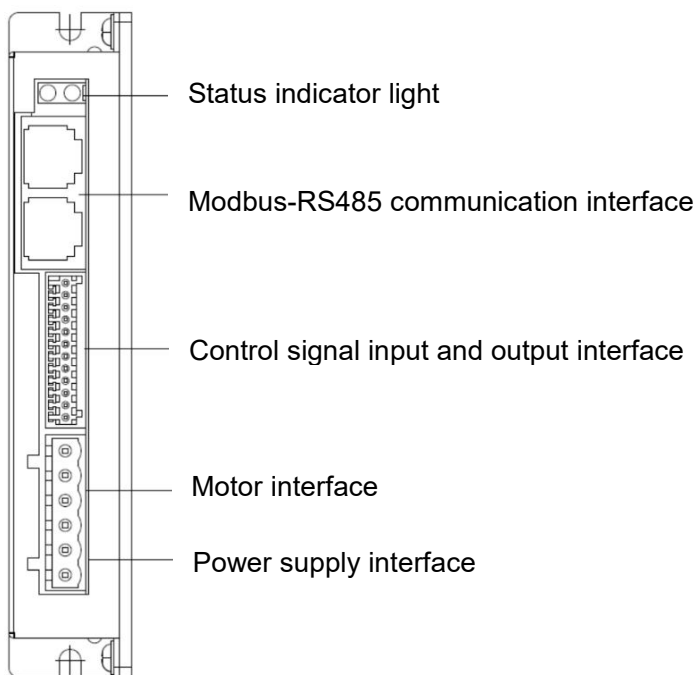

**Driver side wiring diagram**

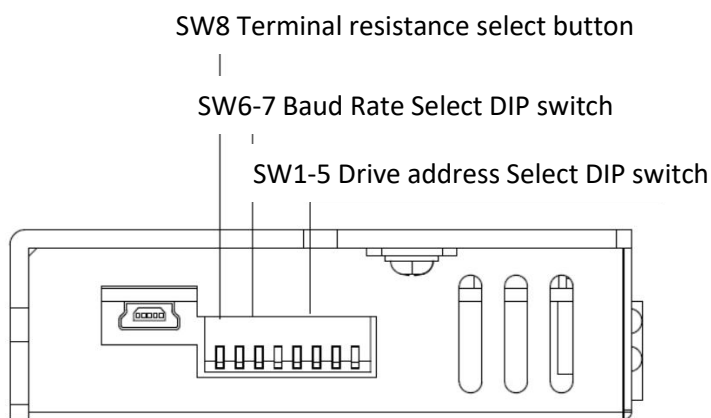

**Final drive top diagram**



**Attention!**

- The personnel involved in wiring must have professional ability.
- No live wiring.
- The wiring can only be carried out after the installation is firm.
- Do not connect the power supply wrong, the input voltage should not exceed 50VDC.

## 4.2 Port Definition

### 4.2.1 Status light

Identification	Name	Function
PWR	Power indicator light	When the power is on, the green indicator lights up.
ALM	Alarm light	Current is overcurrent, the indicator blinks once; In case of overvoltage, the indicator blinks twice; Under voltage, the indicator blinks three times;

### 4.2.2 MODBUS communication port

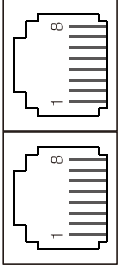
Port	Lead	Symbol	Function
	1	RS-485-A	Data communication interface
	2	RS-485-B	
	3	NC	Reserve
	4	NC	Reserve
	5	RS-485-GND	Grounded common terminal
	6	NC	Reserve
	7	NC	Reserve
	8	NC	Reserve

### 4. 2. 3 Control signal input/output port

The following is the specific definition and functions of the input and output of the DM556PR. The input and output functions can be customized through the register address 2310h-2325h. For example, the input signal can also be configured with stop, emergency stop, probe and other functions. The output can be configured with alarm, in place, brake, output signal and other functions.

Port	Lean	Symbol	Name	Function
	1	X0	Single-ended input port	It is isolated from the external control interface by optocoupler. The driver is compatible with the common negative and common positive connection method and supports 24V signal input.
	2	X1		
	3	X2		
	4	X3		
	5	X4		
	6	X5		
	7	X6		
	8	XCOM	Single end input port common end	Common terminal: Supports common cathode and common anode connections
	9	Y0	Single end outlet	Support common negative connection mode, can support high level and low level effective controller
	10	Y1		
	11	Y2		
	12	YCOM	Single end outlet common end	Common terminal: Supports common cathode and common anode connections

### 4. 2. 4 Power input/motor output port

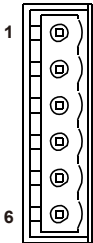
Port	Lean	Symbol	Name	Function
	1	A+	Motor interface	Two phase stepper motor wiring port
	2	A-		
	3	B+		
	4	B-		
	5	V+	Power supply interface	DC24-50V
	6	V-		

### 4.3 Dial setting

DM556PR bus stepper motor driver uses 8-bit dial switch to set driver address, communication baud rate and terminal resistance, detailed description is as follows:

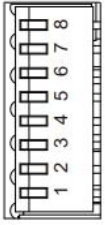
Port	Lean	Symbol	Name	Function
	1	SW1	Code dip switch	Drive address setting
	2	SW2		
	3	SW3		
	4	SW4		
	5	SW5		Communication baud rate setting
	6	SW6		
	7	SW7		
	8	SW8		

#### 4.3.1 Communication baud rate setting

SW6	SW7	Baud rate
ON	ON	9600
OFF	ON	19200
ON	OFF	38400
OFF	OFF	115200

#### 4.3.2 Terminal resistance setting

SW8	120 OHM terminal resistance effective
OFF	Invalid
ON	valid

The following is the terminal resistance dialing situation according to the different use scenarios. Please dial the code according to the actual use scenario, otherwise it may cause abnormal communication and other conditions. At the same time, please ground according to the standard wiring requirements to avoid communication interference.

PLC/ Communication master station	Single drive	Cascading multiple drivers (two or more)
Yes and dial the terminal resistance	No dialing	Last call
Terminal resistance is present but not dialed	To dial code	First and last dial
No terminal resistance (and no additional)	To dial code	First and last dial

### 4.3.3 Terminal resistance setting

This driver uses RS-485 bus and can control up to 30 drivers at the same time. The communication address of the driver is set by a 5-bit dial switch, and the address setting range is 0-31, where address 0 is reserved for the system. When the address of the driver is set to be greater than 31, it needs to be set and saved by the upper debugging software, and the switch needs to be set to OFF. As shown in the following table:

SW5	SW4	SW3	SW2	SW1	Address
OFF	OFF	OFF	OFF	OFF	0
OFF	OFF	OFF	OFF	ON	1
OFF	OFF	OFF	ON	OFF	2
OFF	OFF	OFF	ON	ON	3
OFF	OFF	ON	OFF	OFF	4
OFF	OFF	ON	OFF	ON	5
OFF	OFF	ON	ON	OFF	6
OFF	OFF	ON	ON	ON	7
OFF	ON	OFF	OFF	OFF	8
OFF	ON	OFF	OFF	ON	9
OFF	ON	OFF	ON	OFF	10
OFF	ON	OFF	ON	ON	11
OFF	ON	ON	OFF	OFF	12
OFF	ON	ON	OFF	ON	13
OFF	ON	ON	ON	OFF	14
OFF	ON	ON	ON	ON	15
ON	OFF	OFF	OFF	OFF	16
ON	OFF	OFF	OFF	ON	17
ON	OFF	OFF	ON	OFF	18
ON	OFF	OFF	ON	ON	19
ON	OFF	ON	OFF	OFF	20
ON	OFF	ON	OFF	ON	21
ON	OFF	ON	ON	OFF	22
ON	OFF	ON	ON	ON	23
ON	ON	OFF	OFF	OFF	24
ON	ON	OFF	OFF	ON	25
ON	ON	OFF	ON	OFF	26
ON	ON	OFF	ON	ON	27
ON	ON	ON	OFF	OFF	28
ON	ON	ON	OFF	ON	29
ON	ON	ON	ON	OFF	30
ON	ON	ON	ON	ON	31

### 4. 4 Input/output port operation

DM556PR driver provides 7 channels of photoelectric isolation programmable input interface, compatible with common negative and common positive connection, 3 channels of output interface, support common negative connection mode, can also support high level and low level effective controller.

The 7-channel (X0-X6) programmable input signal is isolated from the external control interface through optocoupler, and the driver is compatible with the common negative and common positive connection method inside, as shown in the following figure

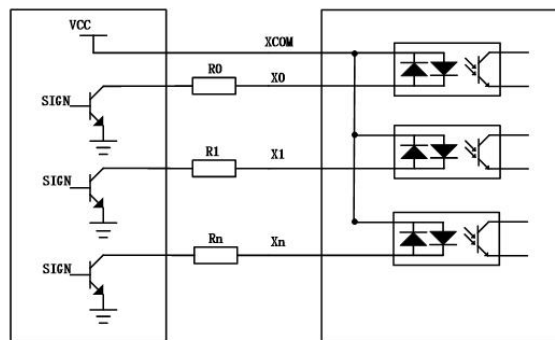

Input terminal connection reference circuit

The level pulse width of the input signal needs to be greater than 10ms, otherwise the driver may not respond properly. The timing diagram of X0-X6 is shown in the figure below.

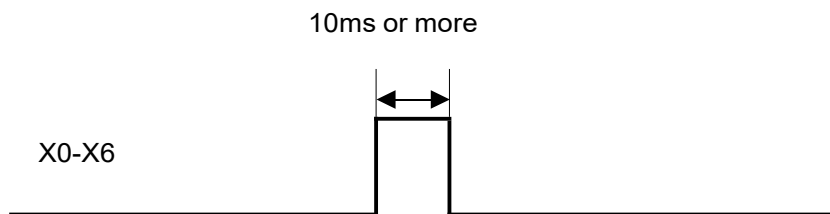

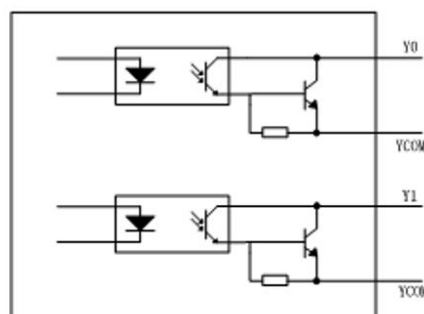

X0-X6 timing diagram

The driver provides 3 optocoupler isolated output terminals, and the wiring is as follows:



## Chapter 5 Driver Status Indicators

The DM556PR driver mainly has the following alarm information. After the driver alarms, the alarm indicator flashes several times according to the alarm code. The alarm code and handling method are as follows.

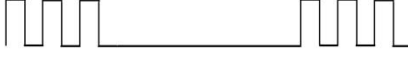
Fault code	Fault information	ALM indicator blinking	Resetting
Err1:0x01	Overcurrent or interphase short circuit		Power-off reset
Err2:0x02	Overvoltage of supply		Automatic restoration of standard voltage
Err3:0x03	Undervoltage of supply		Automatic restoration of standard voltage

## Chapter 6 General Troubleshooting methods

phenomenon	Possible situation	Solution measure
Motor failure	The power light is off	Check the power supply circuit. The power supply is normal
	The motor locks the shaft but does not turn	The IO signal is weak and the signal current is increased
	Too little speed	Selection speed
	Whether the release signal MF is connected	Will release the signal MF does not connect
	Instruction input error	Check whether the upper computer has a switch output
Motor steering error	Motor reversal	Replace motor wiring sequence or adjust instruction direction
	The motor line has a break	Check whether the cable is in poor contact
	The motor has only one direction	Input port damage
Alarm indicator light	The motor wire is connected incorrectly	Check the wiring
	The voltage is too high or low	Check power supply
	The motor or drive is damaged	Replace the motor or drive
Wrong position or speed	Signal interference	Eliminate interference, reliable grounding
	Instruction input error	Check the upper computer instructions to ensure correct output
	Speed setting error	Check the DIP switch status and connect it correctly
	Motor tripping	Check whether the command speed is too large and the motor selection is small
The driver terminal is burned out	Short-circuit between terminals	Check the power polarity or external short circuit
	The internal resistance between terminals is too large	Check whether excess solder is added to the wire and wire connection to form tin pellets
Motor stalling	The acceleration and deceleration time is too short	Reduce the command acceleration or increase the driver filter parameter
	Motor torque too small	Select high torque motor
	Heavy load	Check the load weight and quality, adjust the mechanical structure
	Too little current	Check dip switches to increase the output current of the driver