

REV.	REVISION RECORD	BY	DATE
0	ORIGIN	LDJ	6.26.2025

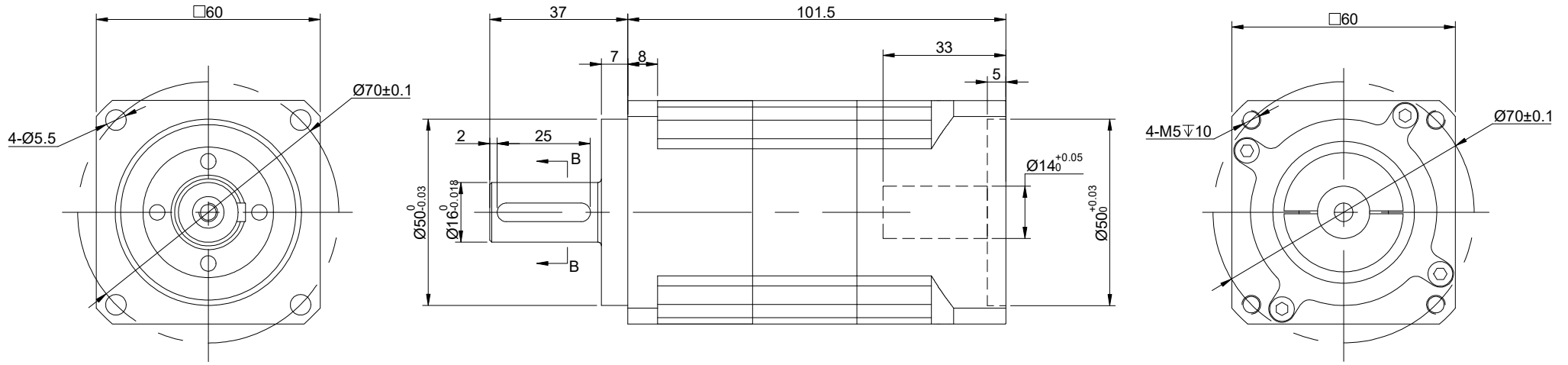

SPECIFICATION	CONNECTION	VALUE
GEAR RATIO		20
EFFICIENCY		94%
BACKLASH@NO-LOAD(arcmin)		<=5
MAX.PERMISSIBLE TORQUE(Nm)[lb-in]		45.00[398.28]
MOMENT PERMISSIBLE TORQUE(Nm)[lb-in]		90.00[796.57]
SHAFT MAXIMUM AXIAL LOAD(N)		630
SHAFT MAXIMUM RADIAL LOAD(N)		1530
GEARBOX MATCHING MOTOR'S INPUT SHAFT LENGTH (mm)		MAX 33
RATED INPUT SPEED(RPM)		3000
MAX. INPUT SPEED(RPM)		6000
NOISE(dB)		<=60
WATERPROOF RATING		IP65
LIFE(h)		20000
WORKING TEMPERATURE		-20°C~150°C[-4°F~302°F]

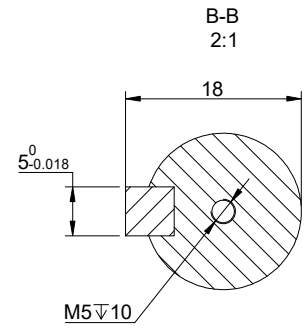

DIMENSIONS ARE IN MILLIMETERS.
TOLERANCES AS BELOW:
DECIMALS ANGLES
X ±0.5 ±2°
X.X ±0.25
X.XX ±0.13

THIRD ANGLE PROJECTION	
SIGNATURE	DATE
DRN LDJ	6.26.2025
APVD LJ	6.26.2025

STEPPERONLINE®

HELICAL PLANETARY GEARBOX

HTG60-G20

REV.	1	SCALE	2:3	DWG NO.	A4696
------	---	-------	-----	---------	-------