



# DM860EC

## Bus stepper driver instruction manual

Version: V1.0



©2025 All Rights Reserved

Address: 15-4, #799 Hushan Road, Jiangning, Nanjing, China

Tel: 0086-2587156578

Web: [www.omc-stepperonline.com](http://www.omc-stepperonline.com)

Sales: [sales@stepperonline.com](mailto:sales@stepperonline.com)

Support: [technical@stepperonline.com](mailto:technical@stepperonline.com)

## Catalogue

Revision history .....	1
Introduction .....	2
Chapter 1 Overview .....	3
1.1 Product introduction .....	3
1.2 Peculiarity .....	3
1.3 Application field .....	3
Chapter 2 Performance Indicators .....	4
2.1 EtherCAT characteristic .....	4
2.2 Electrical characteristic .....	4
2.3 Using environment .....	4
Chapter 3 Installation .....	5
3.1 Mounting dimension .....	5
3.2 Installation Methods .....	5
Chapter 4 Driver Ports and Wiring .....	6
4.1 Wiring diagram .....	6
4.2 Port Definition .....	7
4.2.1 Debugging interface .....	7
4.2.2 Status light .....	7
4.2.3 EtherCAT communication port .....	8
4.2.4 Input/output port .....	8
4.2.5 Motor output port .....	8
4.2.6 Power input port .....	8
4.3 Input/output port operation .....	8
Chapter 5 Driver Status Indicators .....	10
Chapter 6 General Troubleshooting methods .....	11

## Revision history

Version	Description	Date	Remark
V1.0	First edition release	2025.5.10	

## Introduction

Thank you for using this stepper drive.

Before using this product, be sure to read this manual carefully to understand the necessary safety information, precautions, and operation methods.

The wrong operation can lead to extremely serious consequences.

## Statement

The design and manufacture of this product does not have the ability to protect personal safety from the threat of mechanical systems. Users are requested to consider safety protection measures during the design and manufacture of mechanical systems to prevent accidents caused by improper operation or abnormal products.

Due to product improvements, the contents of the manual are subject to change without notice.

Our company will not be responsible for any modification of the product by the user.

When reading, please note the following marks in the manual:



Remind you to pay attention to the main points in the text.



Indicates that improper operations may result in personal injury or equipment damage.

# Chapter 1 Overview

## 1. 1 Product introduction

DM860EC bus stepper servo driver is a digital stepper driver based on the addition of EtherCAT bus communication function, while supporting intelligent motion control function. The DM860EC bus stepper servo driver supports the COE protocol as a standard EtherCAT slave driver unit supporting the market mainstream master controller.

## 1. 2 Peculiarity

- New generation 32-bit DSP technology, high cost performance, good stability, low noise, low vibration
- The working voltage ranges from AC20V~80V/DC30-110V
- The working current is adjustable to a maximum of 6A
- Based on 100BASE-TX Ethernet transmission standard, transmission rate up to 100Mbps, full-duplex communication
- Supports CANopen over EtherCAT (CoE) and complies with CiA 402 standards
- Cyclic Sync Position, Profile Position, Profile Velocity, Homing and other working modes are supported
- A double-port RJ45 connector is used for EtherCAT communication
- Four optical isolation input ports with 12V to 24V input
- Two optical isolation output ports
- Subdivision 400~51200 arbitrary Settings, support electronic gear
- Smooth and accurate current control, low motor heat
- Has over voltage, under voltage, over current and other protection functions

## 1. 3 Application field

Mainly used in lithium industry equipment, 3C non-standard equipment, marking machine, stage lighting and other automation equipment.

## Chapter 2 Performance Indicators

### 2.1 EtherCAT characteristic

Argument		DM860EC	
EtherCAT communication indicators	Link layer	100BASE-TX Ethernet	
	Communication port	RJ45 standard network port	
	Network topology	Lines, trees, stars, etc	
	Baud rate	100Mbps full duplex communication	
	Synchronization manager		SM0: mailbox received
			SM1: sent by email
			SM2: Process data output RPDO
			SM3: Process data is entered into TPDO
Communication mode		SM synchronous mode	
		DC synchronization mode. The synchronization period ranges from 250us to 4000us	
Application layer protocol	COE: CANopen Over EtherCAT		
Cia402 working mode	(Cyclic Synchronous Position Mode); (Profile Position Mode); (Profile Velocity Mode); (Homing Mode);		

### 2.2 Electrical characteristic

Argument	DM860EC			
	Minimum value	Typical value	Maximum value	Unit
Continuous output current	0	-	6.0	A
Input supply voltage	24	24/48	80	Vdc
Logic input current	5	10	50	mA
Logic input voltage	12	24	24	V
Insulation resistance	100	-	-	MΩ

### 2.3 Using environment

Cooling mode	Natural cooling	
Use environment	Use occasion	Try to stay away from other heating equipment, avoid dust, oil mist, corrosive gas, strong vibration places, flammable gas and conductive dust are prohibited
	Temperature	0°C~50°C
	Humidity	40-90%RH (non-condensation)
	Vibration	10~55Hz/0.15mm
Storage temperature	-20°C~+70°C	

## Chapter 3 Installation

### 3.1 Mounting dimension

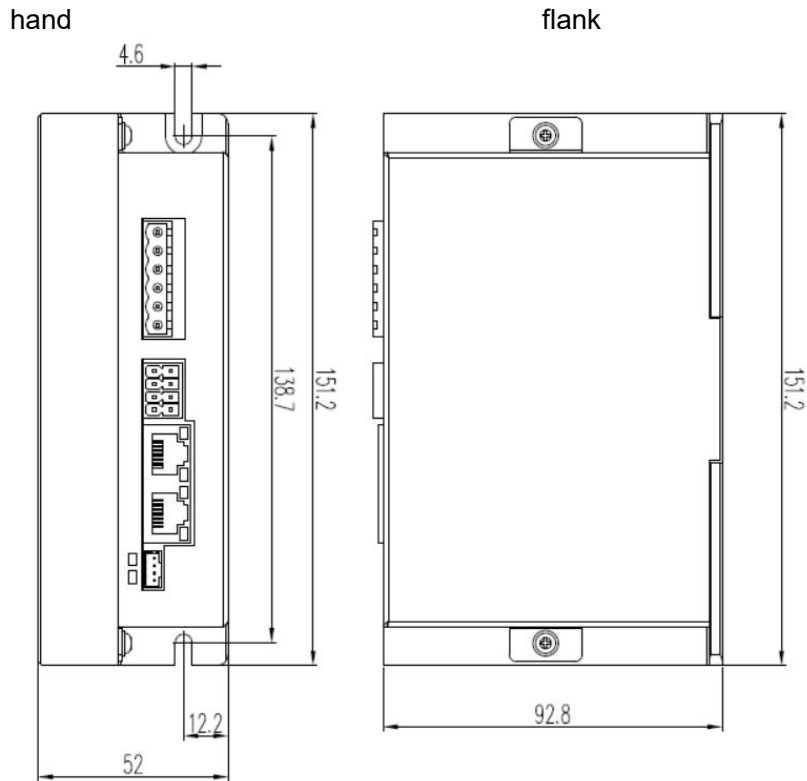

Installation size drawing(unit: mm)

### 3.2 Installation Methods

When installing the driver, please use the upright side installation to form strong air convection on the driver surface; If necessary, install a fan close to the driver to force the heat to dissipate to ensure that the driver works within the reliable operating temperature range (the reliable operating temperature of the driver is usually within 50°C, and the operating temperature of the motor is within 80°C).

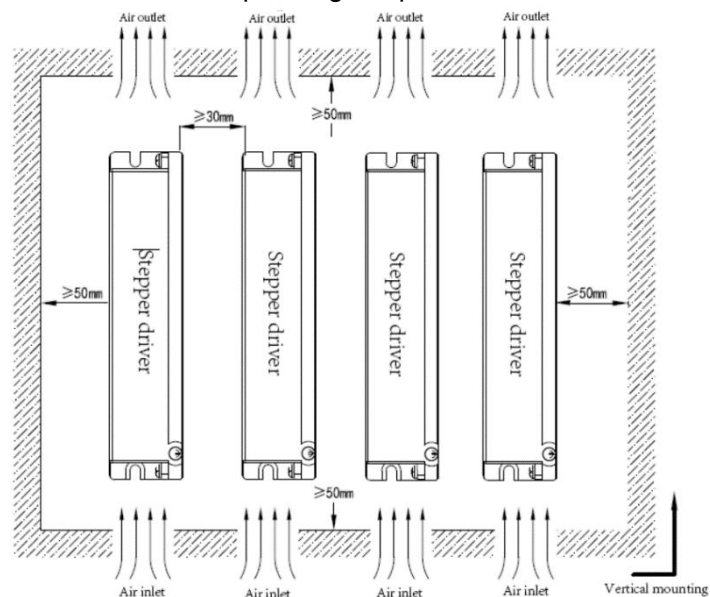

## Chapter 4 Driver Ports and Wiring

### 4. 1 Wiring diagram

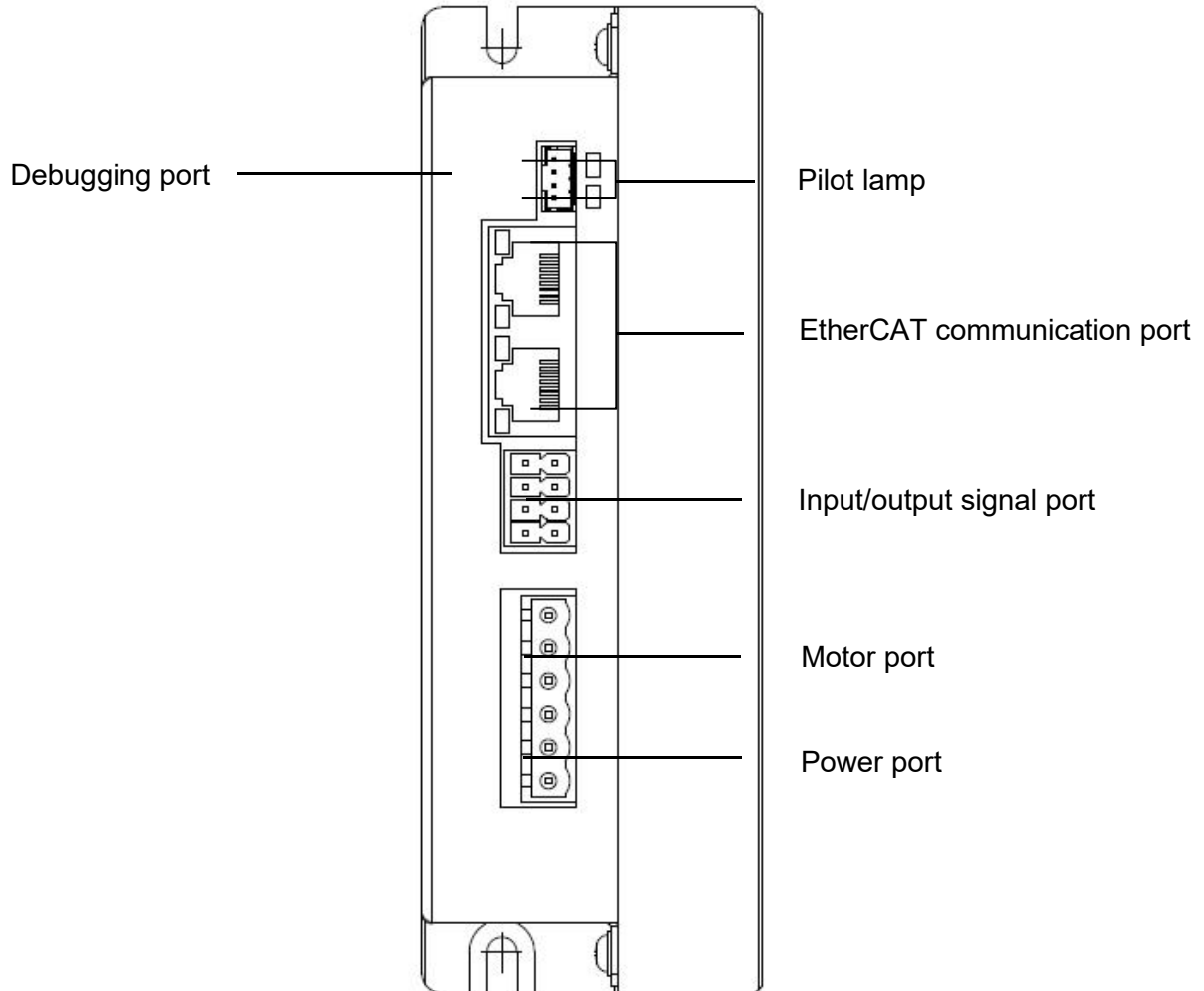

**Attention!**

- The personnel involved in wiring must have professional ability.
- No live wiring.
- The wiring can only be carried out after the installation is firm.
- Do not connect the power supply wrong, the input voltage should not exceed AC80V/DC110V.

## 4. 2 Port Definition

### 4. 2. 1 Debugging interface

Port	Symbol	Name	Function
	TX	Debugging interface	Connect to debug software.
	RX		
	GND		
	NC		

### 4. 2. 2 Status light

Name	Color	Status	Function
PWR	Green	ON	Power is on, the green indicator lights up
ALM	Red	Flash 1 time	Overcurrent
		Flash 2 time	Overvoltage
		Flash 3 time	Undervoltage
		Flash 6 time	Communication error
		Flash 8 time	Sensor error
RUN	Green	OFF	INIT Status or power-off status
		Blinking	Pre-Operational status
		Single Flash	Safe-Operational status
		Flickering	BootStrap status
		ON	Operational status
ERR	Red	OFF	No error or power failure status
		Flickering	EEPROM load error
		Single Flash	Status register error
		Double Flash	The process data watchdog timed out
		ON	PDI The watchdog timed out
L/A	Green	OFF	The physical layer link is not established
		ON	The physical layer link is established
		Flickering	The physical layer link has data interaction

### 4. 2. 3 EtherCAT communication port

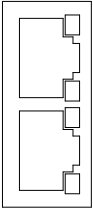
	Symbol		Function
	1	TX+	Two standard RJ45 network ports, support EtherCAT data sending and receiving, site front and back links;
	2	TX-	
	3	RX+	
	4	NC	
	5	NC	
	6	RX-	
	7	NC	
	8	NC	

### 4. 2. 4 Input/output port

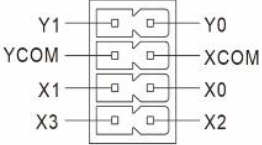
	Symbol	Name	Function
	Y0	Output terminal 0	Digital output signal
	Y1	Output terminal 1	
	XCOM	Input common terminal	Input signal public end
	YCOM	Output common terminal	Output signal common end
	X0	Input terminal 0	Single-ended digital input signal, total positive connection, support 12V~24V
	X1	Input terminal 1	
	X2	Input terminal 2	
	X3	Input terminal 3	

### 4. 2. 5 Motor output port

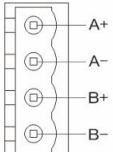
	Symbol	Name	Function
	A+	Motor interface	Two phase stepper motor connector
	A-		
	B+		
	B-		

### 4. 2. 6 Power input port

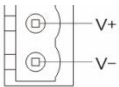
	Symbol	Name	Function
	V+	Power interface	AC20-80V/DC30-110V
	V-		

## 4. 3 Input/output port operation

The driver provides 4 photoelectric isolated input interfaces and 2 optocoupler isolated output signals.

Cables to the input ports are as follows, supporting 12V to 24V voltage:

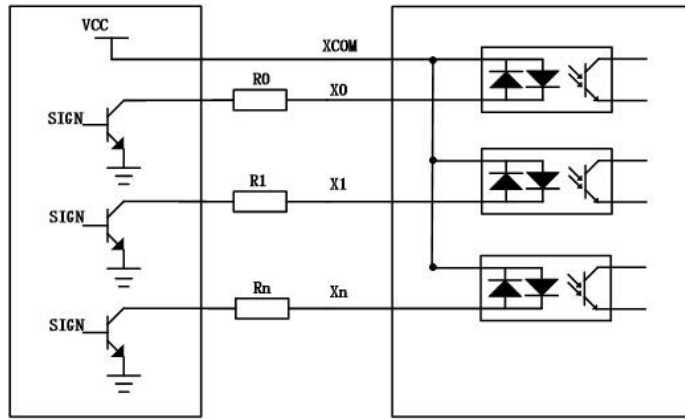

Input terminal connection reference circuit

The level pulse width of the input signal needs to be greater than 10ms, otherwise the driver may not respond properly. The timing diagram of X0-X3 is shown in the figure below.

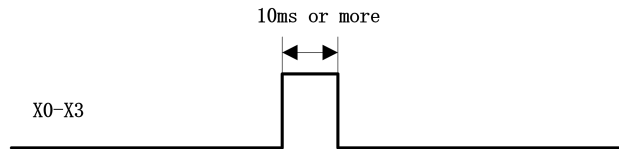

X0-X3 timing diagram

The driver provides two optocoupler isolated output terminals, and the wiring is as follows:

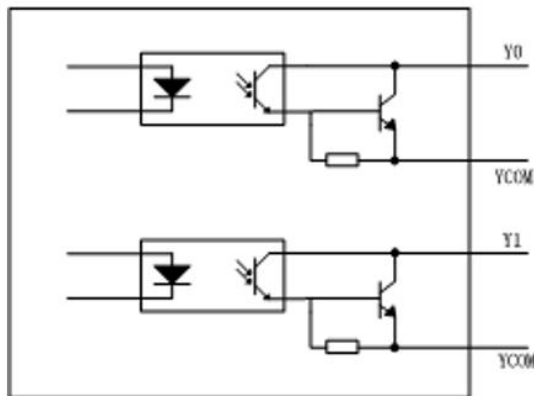

Y0-Y1 output terminal internal circuit

## Chapter 5 Driver Status Indicators

The DM860EC driver has an alarm. After the driver alarms, the alarm indicator state indicates the alarm information of the driver. The specific alarm information is shown in the following table.

<b>Fault code</b>	<b>Fault information</b>	<b>Status light description</b>	<b>Resetting</b>
Err1:0x01	Overcurrent or interphase short circuit	1 red, 1 green	Power-off reset
Err2:0x02	Overvoltage of supply	2red, 1 green	Automatic restoration of standard voltage
Err3:0x03	The power supply voltage is too low.	3 red, 1 green	Automatic restoration of standard voltage
Err3:0x06	Communication error	6 red, 1 green	Resetting
Err3:0x08	Sensor error report	8 red, 1 green	Resetting

## Chapter 6 General Troubleshooting methods

Symptom	Possible causes	Solutions
Motor failure	The power light is off	Check the power supply circuit. The power supply is normal
	The motor locks the shaft but does not turn	The IO signal is weak and the signal current is increased
	Too little speed	Selection speed
	Whether the release signal MF is connected	Will release the signal MF does not connect
	Instruction input error	Check whether the upper computer has a switch output
Motor steering error	Motor reversal	Replace motor wiring sequence or adjust instruction direction
	The motor line has a break	Check whether the cable is in poor contact
	The motor has only one direction	Input port damage
Alarm indicator light	The motor wire is connected incorrectly	Check the wiring
	The voltage is too high or low	Check power supply
	The motor or drive is damaged	Replace the motor or drive
Wrong position or speed	Signal interference	Eliminate interference, reliable grounding
	Instruction input error	Check the upper computer instructions to ensure correct output
	Speed setting error	Check the DIP switch status and connect it correctly
	Motor tripping	Check whether the command speed is too large and the motor selection is small
The driver terminal is burned out	Short-circuit between terminals	Check the power polarity or external short circuit
	The internal resistance between terminals is too large	Check whether excess solder is added to the wire and wire connection to form tin pellets
Motor stalling	The acceleration and deceleration time is too short	Reduce the command acceleration or increase the driver filter parameter
	Motor torque too small	Select high torque motor
	Heavy load	Check the load weight and quality, adjust the mechanical structure
	Too little current	Check dip switches to increase the output current of the driver