

STEPPERONLINE®

CL86EC

Bus stepper driver instruction manual

Version: V1.0



©2025 All Rights Reserved

Address: 15-4, #799 Hushan Road, Jiangning, Nanjing, China

Tel: 0086-2587156578

Web: www.omc-stepperonline.com

Sales: sales@stepperonline.com

Support: technical@stepperonline.com

Catalogue

Revision history	1
Introduction	2
Chapter 1 Overview	3
1.1 Product introduction	3
1.2 Peculiarity	3
1.3 Application field	3
Chapter 2 Performance Indicators	4
2.1 EtherCAT characteristic	4
2.2 Electrical characteristic	4
2.3 Using environment	4
Chapter 3 Installation	5
3.1 Mounting dimension	5
3.2 Installation Methods	5
Chapter 4 Driver Ports and Wiring	6
4.2 Port Definition	7
4.2.1 Status light	7
4.2.2 EtherCAT communication port	7
4.2.3 Control signal input/output port	8
4.2.4 Power input/motor output port	8
4.2.5 Encoder input port	9
4.3 Input/output port operation	9
Chapter 5 Driver Status Indicators	11
Chapter 6 General Troubleshooting methods	12

Revision history

Version	Description	Date	Remark
V1.0	First edition release	2025.5.10	

Introduction

Thank you for using this stepper drive.

Before using this product, be sure to read this manual carefully to understand the necessary safety information, precautions, and operation methods.

The wrong operation can lead to extremely serious consequences.

Statement

The design and manufacture of this product does not have the ability to protect personal safety from the threat of mechanical systems. Users are requested to consider safety protection measures during the design and manufacture of mechanical systems to prevent accidents caused by improper operation or abnormal products.

Due to product improvements, the contents of the manual are subject to change without notice.

Our company will not be responsible for any modification of the product by the user.

When reading, please note the following marks in the manual:



Remind you to pay attention to the main points in the text.



Indicates that improper operations may result in personal injury or equipment damage.

Chapter 1 Overview

1.1 Product introduction

CL86EC Bus type stepper motor driver is based on the digital closed-loop stepper drive with bus communication and single axis controller functions. The bus communication adopts standard RJ-45 interface, and the protocols supporting standard include EtherCAT protocol, COE application protocol, and host computer debugging interface SCI.

1.2 Peculiarity

- New generation 32-bit DSP technology, high cost performance, good stability, low noise, low vibration
- The working voltage ranges from AC18-80V/DC30-110V
- The working current is adjustable to a maximum of 6A
- Based on 100BASE-TX Ethernet transmission standard, transmission rate up to 100Mbps, full-duplex communication
- Supports CANopen over EtherCAT (CoE) and complies with CiA 402 standards
- Cyclic Sync Position, Profile Position, Profile Velocity, Homing and other working modes are supported
- A double-port RJ45 connector is used for EtherCAT communication
- Subdivision 400~51200 arbitrary Settings, support electronic gear
- Smooth and accurate current control, low motor heat
- Has over voltage, under voltage, over current and other protection functions

1.3 Application field

This product is suitable for various medium and large scale automation equipment and instrument applications. For example: 3C non-standard industry, battery industry, photovoltaic industry TOP customer applications, mainly used for real-time communication and monitoring of a large number of stepping product data at the customer site, which can significantly reduce client control costs.

Chapter 2 Performance Indicators

2.1 EtherCAT characteristic

Argument		CL86EC	
EtherCAT communication indicators	Link layer	100BASE-TX Ethernet	
	Communication port	RJ45 standard network port	
	Network topology	Lines, trees, stars, etc	
	Baud rate	100Mbps full duplex communication	
	Synchronization manager		SM0: mailbox received
			SM1: sent by email
			SM2: Process data output RPDO
			SM3: Process data is entered into TPDO
Communication mode		SM synchronous mode	
		DC synchronization mode. The synchronization period ranges from 250us to 4000us	
Application layer protocol	COE: CANopen Over EtherCAT		
Cia402 working mode	(Cyclic Synchronous Position Mode); (Profile Position Mode); (Profile Velocity Mode); (Homing Mode);		

2.2 Electrical characteristic

Argument	CL86EC			
	Minimum	Typical	Maximum	Unit
Continuous output current	-	-	6.0	A
Input supply voltage	18	-	80	Vac
Input supply voltage	30	48	110	Vdc
Logic input current	5	10	50	mA
Logic input voltage	12	24	24	V
Insulation resistance	100	-	-	MΩ

2.3 Using environment

Cooling mode	Natural cooling	
Use environment	Use occasion	Stay away from other heating equipment, avoid dust, oil mist, corrosive gas, strong vibration places, flammable gas and conductive dust are prohibited
	Temperature	0°C~50°C
	Humidity	40-90%RH (non-condensation)
	Vibration	10~55Hz/0.15mm
Storage temperature	-20°C~+70°C	

Chapter 3 Installation

3.1 Mounting dimension

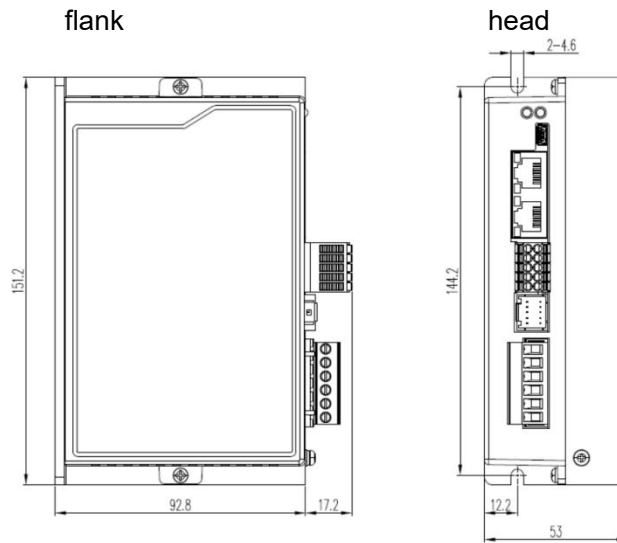

Installation size drawing (unit: mm)

3.2 Installation Methods

When installing the driver, please use the upright side installation to form strong air convection on the driver surface; If necessary, install a fan close to the driver to force the heat to dissipate to ensure that the driver works within the reliable operating temperature range (the reliable operating temperature of the driver is usually within 50°C, and the operating temperature of the motor is within 80°C).

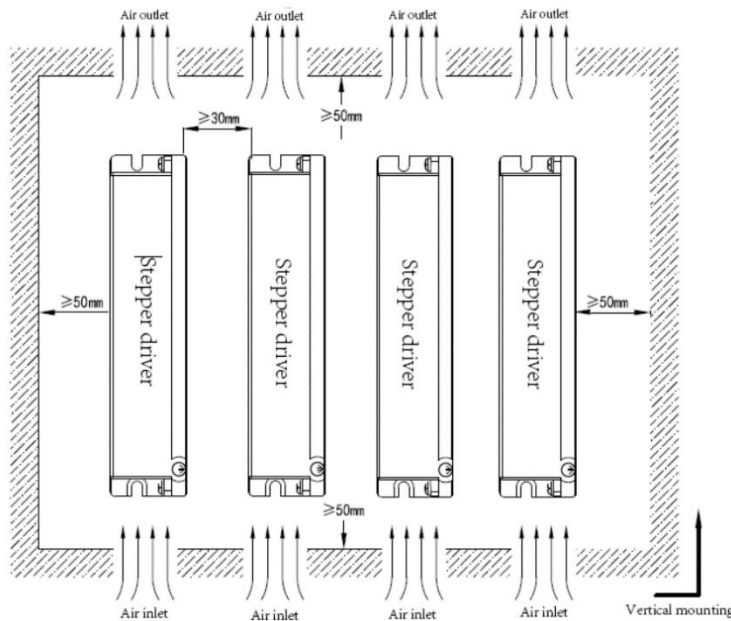

Chapter 4 Driver Ports and Wiring

4.1 Wiring diagram

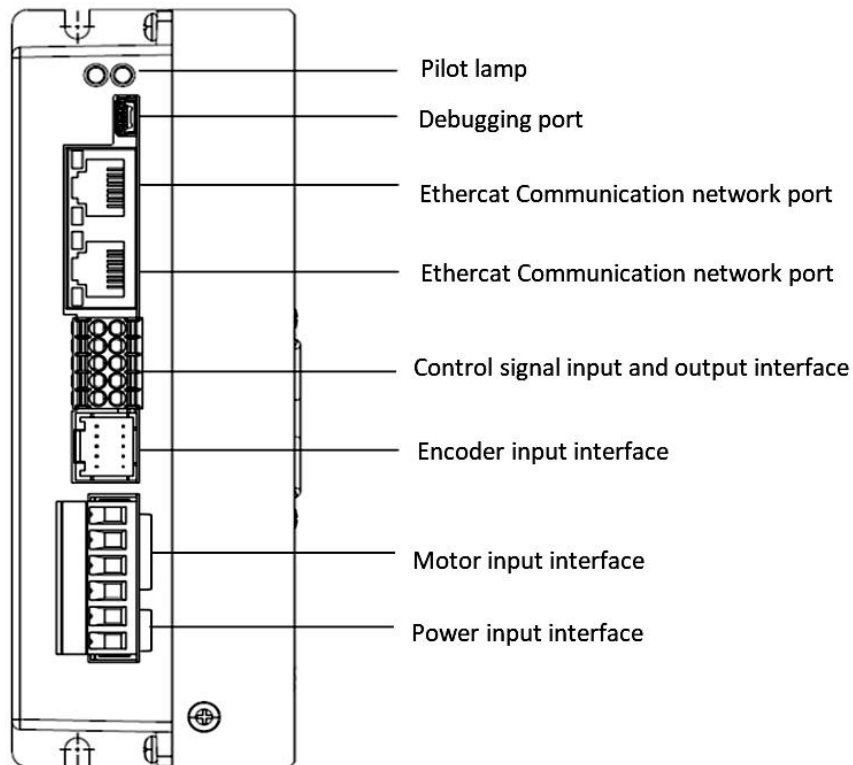

Attention!

- The personnel involved in wiring must have professional ability.
- No live wiring.
- The wiring can only be carried out after the installation is firm.
- Do not connect the power supply wrong, the input voltage should not exceed AC80V/DC110VDC.

4.2 Port Definition

4.2.1 Status light

Identification	Name	Function
PWR	Power indicator light	When the power is on, the green indicator lights up.
ALM	Alarm light	Overcurrent: 1 blink; Overvoltage: 2 blinks; Undervoltage: 3 blinks; Phase Error: 4 blinks; Misalignment: 5 blinks; Communication Failure: 6 blinks
RUN	Running status light	When INIT, the status light OFF; When Pre-Operational, the status light Blinking; When Safe-Operational, the status light Blinking SingleFlash; When Operational, the status light ON;
ERR	Error light	When No Error, the error light OFF; When Extra Error, the error light Blinking; When Sync Error, the error light Single Flash; When Watch-dog Error, the error light DoubleFlash;
L/A	Network communication indicator	If the physical link is not connected (the network cable is not properly connected or faulty), the indicator is OFF; When the physical link is connected, the indicator is ON; When the physical layer link has data interaction, the indicator blinks;

4.2.2 EtherCAT communication port

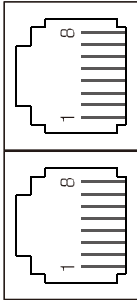
Port	Lead	Symbol	Function
	This driver supports two standard RJ45 network ports, supports EtherCAT data sending and receiving, and links to and from the site.		
	1	NC	Reserve
	2	NC	Reserve
	3	RX-	Data receiving negative end
	4	NC	Reserve
	5	NC	Reserve
	6	RX+	Data receiving terminal
	7	TX-	Data sending negative end
	8	TX+	Data sending end

4.2.3 Control signal input/output port

The following is the specific definition and functions of the input and output of the CL86EC. You can customize the input and output functions through the register address 2310h-2325h, such as the input signal can also be configured with stop, emergency stop, probe and other functions. The output can be configured with alarm, in place, brake, Z signal output signal and other functions.

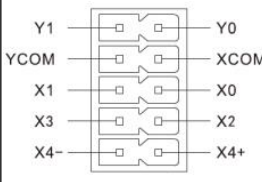
Port	Lead	Name	Default value	Function
	X0	Input terminal X0	origin	4 single-ended digital inputs (XCOM total), compatible with 5-24V signals, supports both common anode and cathode connections
	X1	Input terminal X1	Positive limit	
	X2	Input terminal X2	Negative limit	
	X3	Input terminal X3	To be defined	
	X4+	Differential input terminal X4+	To be defined	1 differential digital input signal, compatible with 5-24V signal, supports both common anode and cathode connections
	X4-	Differential input terminal X4-	To be defined	
	XCOM	Input common terminal	Input signal public end	Input signal public end
	YCOM	Output common terminal	Output signal common end	Output signal common end
	Y0	Output terminal Y0	To be defined	Two single-ended digital output signals
	Y1	Output terminal Y1	To be defined	

4.2.4 Power input/motor output port

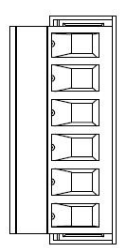
Port	Lead	Name	Default value	Function
	1	A-	Motor interface	Two phase stepper motor connector
	2	A+		
	3	B-		
	4	B+		
	1	AC	Power interface	DC30-80V AC18-80V
	2	AC		

4.2.5 Encoder input port

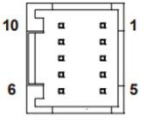
	Serial number	Symbol	Name	Function
	1	NC	Reserve	Reserve
	2	NC		
	3	EZ+	Encoder Z phase input positive/negative end	Encoder Z channel positive input/negative input
	4	EZ-		
	5	GND	Encoder power grounding	Encoder power grounding
	6	+5V	Encoder power Supply	Encoder 5V power supply
	7	EA-	Encoder phase A input positive/negative end	Encoder A channel positive input/negative input
	8	EA+		
	9	EB-	Encoder B phase input positive/negative end	Encoder B channel positive input/negative input
	10	EB+		

4.3 Input/output port operation

The driver provides 5 photoelectric isolated input interfaces and 2 optocoupler isolated output signals.

Cables to the input ports are as follows, supporting 12V to 24V voltage:

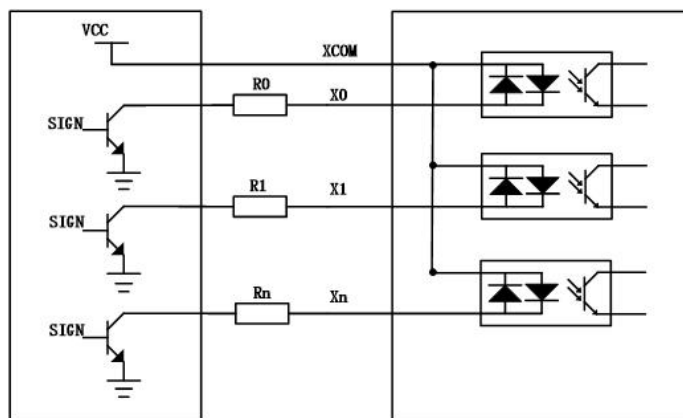

Input terminal connection reference circuit

The level pulse width of the input signal needs to be greater than 10ms, otherwise the driver may not respond properly. The timing diagram of X0-X3 is shown in the figure below.

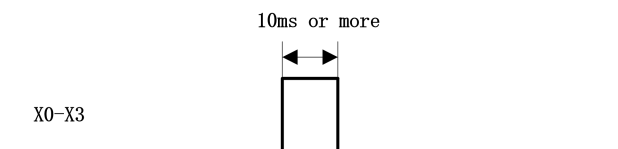

X0-X3 timing diagram



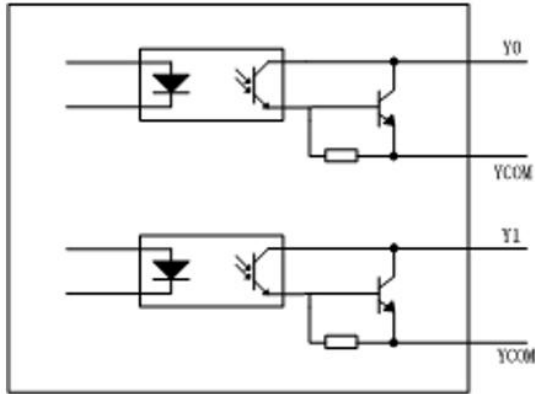



The driver provides two optocoupler isolated output terminals, and the wiring is as follows:

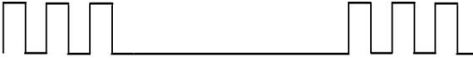

Y0-Y1 output terminal internal circuit

Chapter 5 Driver Status Indicators

The CL86EC driver mainly has the following alarm information. After the driver alarms, the alarm indicator flashes several times according to the alarm code. The alarm code and handling method are as follows. (See the "EtherCAT Series Bus Product Function Manual" for details.)

Fault code	Fault information	ALM indicator blinking	Resetting
Err1:0x01	Overcurrent or interphase short circuit		Power-off reset
Err2:0x02	Overvoltage of supply		Automatic restoration of standard voltage
Err3:0x03	The power supply voltage is too low.		Automatic restoration of standard voltage
Err4:0x04	The motor is connected to the wrong phase		Power-off reset
Err5:0x05	Position overshoot		Power failure, manual reset
Err6:0x06	Communication error		Power failure, manual reset

Chapter 6 General Troubleshooting methods

Symptom	Possible situation	Solutions
Motor failure	The power light is off	Check the power supply circuit. The power supply is normal
	The motor locks the shaft but does not turn	The IO signal is weak and the signal current is increased
	Too little speed	Selection speed
	Whether the release signal MF is connected	Will release the signal MF does not connect
	Instruction input error	Check whether the upper computer has a switch output
Motor steering error	Motor reversal	Replace motor wiring sequence or adjust instruction direction
	The motor line has a break	Check whether the cable is in poor contact
	The motor has only one direction	Input port damage
Alarm indicator light	The motor wire is connected incorrectly	Check the wiring
	The voltage is too high or low	Check power supply
	The motor or drive is damaged	Replace the motor or drive
Wrong position or speed	Signal interference	Eliminate interference, reliable grounding
	Instruction input error	Check the upper computer instructions to ensure correct output
	Speed setting error	Check the DIP switch status and connect it correctly
	Motor tripping	Check whether the command speed is too large and the motor selection is small
The driver terminal is burned out	Short-circuit between terminals	Check the power polarity or external short circuit
	The internal resistance between terminals is too large	Check whether excess solder is added to the wire and wire connection to form tin pellets
Motor stalling	The acceleration and deceleration time is too short	Reduce the command acceleration or increase the driver filter parameter
	Motor torque too small	Select high torque motor
	Heavy load	Check the load weight and quality, adjust the mechanical structure
	Too little current	Check dip switches to increase the output current of the driver