

MODEL NO. LK60-40DL10S3-410 DWG NO. A4548

CUSTOMER'S MODEL: NO MODEL
END COVER COLOR: GREY

REV.	REVISION RECORD	BY	DATE
0	ORIGIN	LJ	5.20.2025

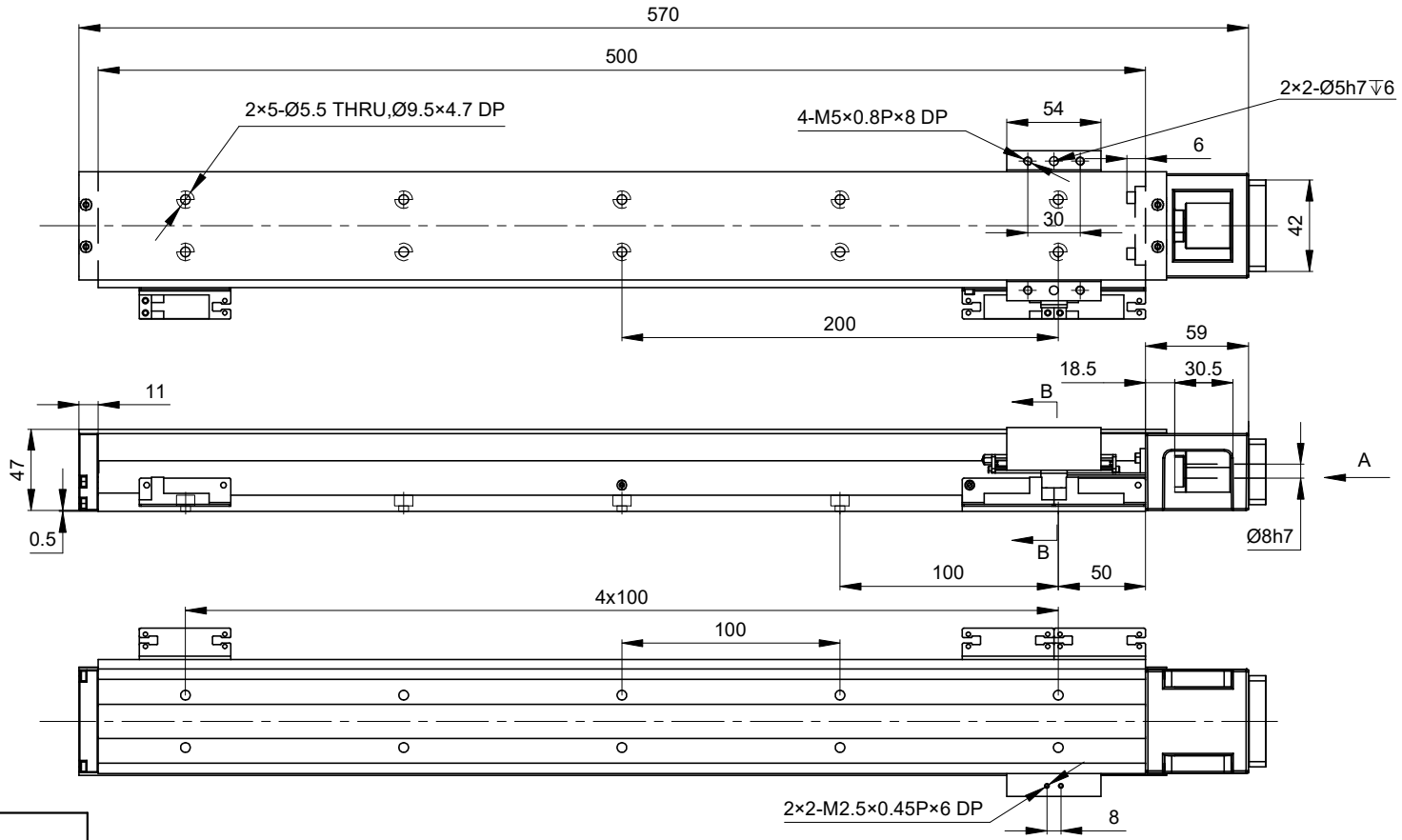
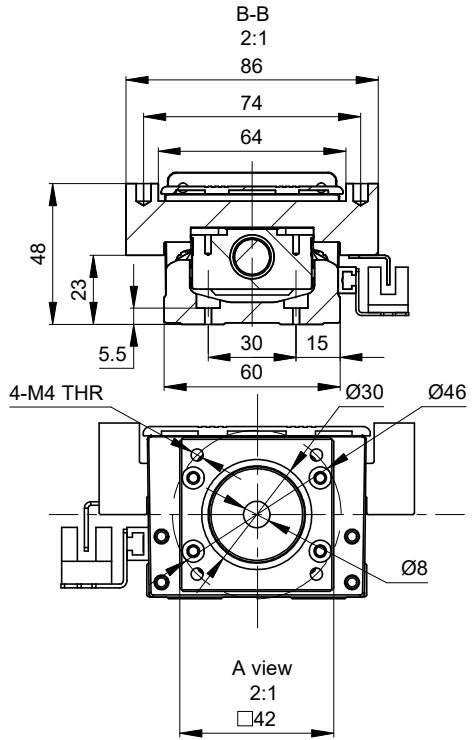

STROKE PITCH(mm)	410	
POSITION ACCURACY (mm)	±0.01	
BALL SCREW LEAD (mm)	10.00	
MAXIMUM SPEED (mm/s)	500.00	
MAXIMUM PAYLOAD(kg)	HORIZONTAL	20.00
	VERTICAL	6.00
RATED THRUST (N)	170.00	
BALL SCREW DIAMETER (mm)	C7/Ø12	
ORIGIN SENSOR	NPN	
INPUT SHAFT LENGTH (mm)	25.00	
INPUT SHAFT DIAMETER (mm)	8.00	
WEIGHT(Kg)[lb]	3.9[8.59]	

THIS DOCUMENT SHALL NOT BE REPRODUCED
NOR SHALL THE INFORMATION CONTAINED
HEREIN BE USED BY OR DISCLOSED TO OTHERS
UNLESS EXPRESSLY AUTHORIZED IN BY WRITING
STEPPERONLINE.

DIMENSIONS ARE IN MILLIMETERS.
TOLERANCES AS BELOW:
DECIMALS ANGLES
X ±0.5 ±2°
X.X ±0.25
X.XX ±0.13

THIRD ANGLE PROJECTION		DATE
SIGNATURE		
DRN	LJ	5.20.2025
APVD	LDJ	5.21.2025

STEPPERONLINE®

STEPPER MOTOR LINEAR ACTUATOR

LK60-40DL10S3-410

REV.	0	SCALE	1:4	DWG NO.	A4548
------	---	-------	-----	---------	-------