

CUSTOMER'S MODEL: NO MODEL
 END COVER COLOR: BLACK

REV.	REVISION RECORD	BY	DATE
0	ORIGIN	MYX	4.22.2025

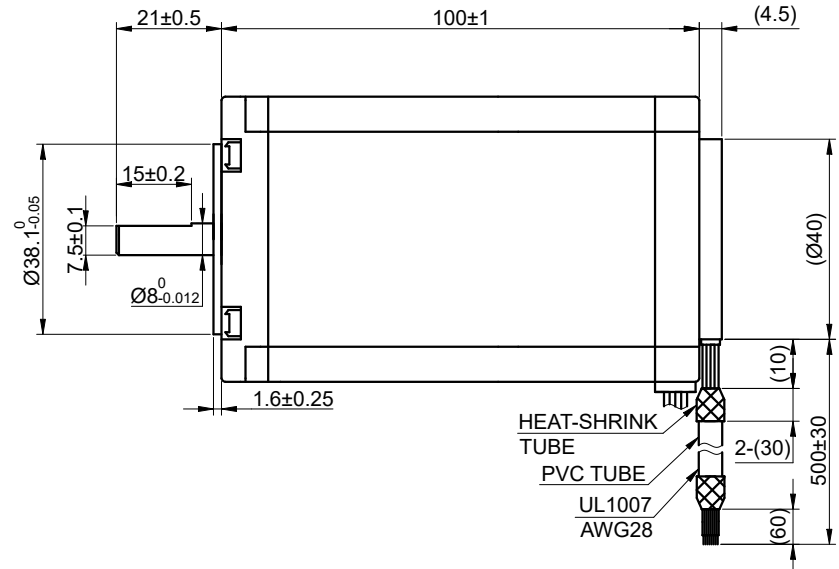
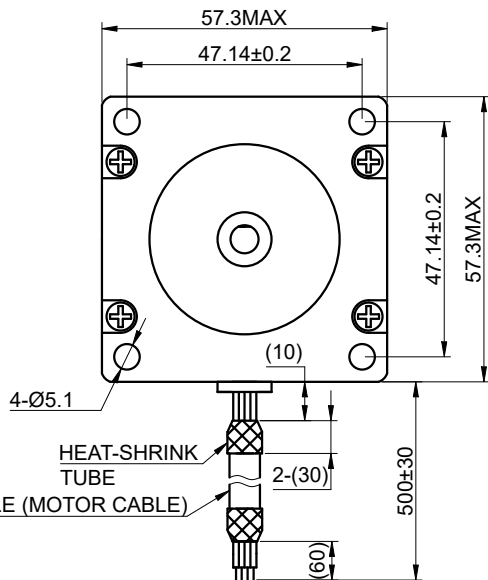

TRVV 4x0.5²BLACK SERVO CABLE (MOTOR CABLE)

ENCODER CONNECTION:1000PPR(4000CPR)								
PIN NO	1	2	3	4	5	6	7	8
LEAD COLOR	BLK	RED	BRN	BLU	ORG	GRN	YEL	WHT
DESCRIPTION	GND	VCC	EA+	EB+	EA-	EB-	EZ+	EZ-

CONNECTION	BIPOLAR
SPECIFICATION	
AMPS/PHASE	5.00
RESISTANCE/PHASE(Ohms)@25°C	0.60±10%
INDUCTANCE/PHASE(mH)@1KHz	2.30±20%
HOLDING TORQUE(Nm)[lb-in]	3.00[26.55]
STEP ANGLE(°)	1.80
STEP ACCURACY(NON-ACCUM)	±5.00%
ROTOR INERTIA(g-cm²)	660
WEIGHT(Kg)[lb]	—
AMBIENT TEMPERATURE	-10°C~50°C[14°F~122°F]
INSULATION CLASS	B 130°C[266°F]
TEMPERATURE RISE	MAX.80°C

COMMENT:
 1.DYNAMIC AXIAL LOAD: 15N MAX
 2.DYNAMIC RADIAL LOAD @ SHAFT LENGTH 20mm: 75N MAX
 3.TMBF 6000h OR MORE @ 24V/300RPM
 4.INSULATION RESISTANCE (NORMAL TEMPERATURE AND HUMIDITY): 100 Mohm
 5.DIELECTRIC STRENGTH 500VAC FOR 1MIN.(BETWEEN THE MOTOR COILS AND THE MOTOR CASE)

MOTOR CONNECTION			
PIN NO	BIPOLAR	LEADS	WINDING
1	A+	GRN	
2	A-	BLK	
3	B+	RED	
4	B-	BLU	

FULL STEP 2 PHASE-Ex.,WHEN FACING MOUNTING END (X)						DIMENSIONS ARE IN MILLIMETERS.	
STEP	A+	B+	A-	B-			TOLERANCES AS BELOW:
							DECIMALS
1	+	+	-	-			X ±0.5
2	-	+	+	-			X.X ±0.25
3	-	-	+	+			X.XX ±0.13
4	+	-	-	+			

STEPPERONLINE®

STEPPER MOTOR

23HS40-5004-ME1K

THIS DOCUMENT SHALL NOT BE REPRODUCED NOR SHALL THE INFORMATION CONTAINED HEREIN BE USED BY OR DISCLOSED TO OTHERS UNLESS EXPRESSLY AUTHORIZED IN BY WRITING STEPPERONLINE.

SIGNATURE		DATE
DRN	MYX	4.22.2025
APVD	LJ	4.22.2025