

CUSTOMER'S MODEL: NO MODEL
 END COVER COLOR: BLACK

REV.	REVISION RECORD	BY	DATE
0	ORIGIN	LJ	4.15.2025

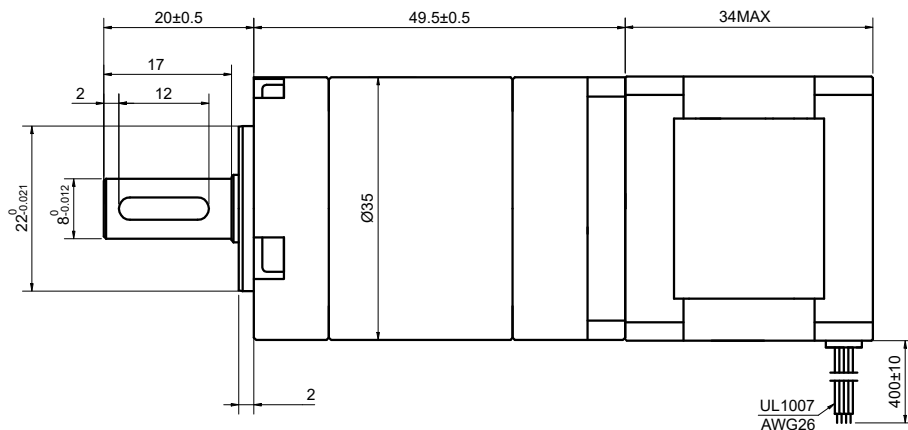
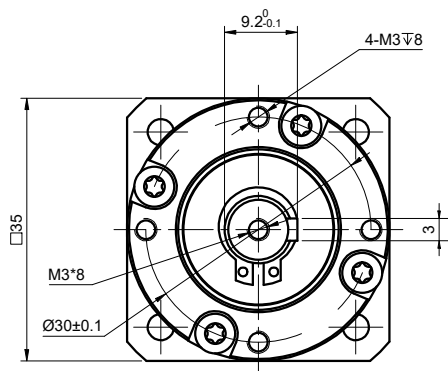

SPECIFICATION	CONNECTION	BIPOLAR
AMPS/PHASE		1.00
RESISTANCE/PHASE(Ohms)@25°C		4.20±10%
INDUCTANCE/PHASE(mH)@1KHz		6.00±20%
HOLDING TORQUE w/o GEARBOX(Nm)[lb-in]		0.18[1.60]
STEP ANGLE w/o GEARBOX(°)		1.80
GEAR RATIO		20
GEAR EFFICIENCY		94%
BACKLASH@NO-LOAD(arcmin)		<=20
MAX.PERMISSIBLE TORQUE(Nm)		8.50
MOMENT PERMISSIBLE TORQUE(Nm)		17.00
AMBIENT TEMPERATURE		-10°C~50°C[14°F~122°F]
INSULATION CLASS		B 130°C[266°F]
TEMPERATURE RISE		MAX.80°C

COMMENT:
 1.DYNAMIC AXIAL LOAD: 50N MAX
 2.DYNAMIC RADIAL LOAD @ SHAFT LENGTH 20mm: 100N MAX
 3.TMBF 6000h OR MORE @ 24V/300RPM
 4.INSULATION RESISTANCE (NORMAL TEMPERATURE AND HUMIDITY): 100 Mohm
 5.DIELECTRIC STRENGTH 500VAC FOR 1MIN.(BETWEEN THE MOTOR COILS AND THE MOTOR CASE)

MOTOR CONNECTION			
PIN NO	BIPOLAR	LEADS	WINDING
1	A+	BLK	
2	A-	GRN	
3	B+	RED	
4	B-	BLU	

FULL STEP 2 PHASE-Ex.,WHEN FACING MOUNTING END (X)						DIMENSIONS ARE IN MILLIMETERS.		
STEP	A+	B+	A-	B-		CCW	TOLERANCES AS BELOW:	
1	+	+	-	-			DECIMALS	
2	-	+	+	-			X ±0.5	ANGLES
3	-	-	+	+			X.X ±0.25	±2°
4	+	-	-	+			X.XX ±0.13	
						THIRD ANGLE PROJECTION		

STEPPERONLINE®

STEPPER MOTOR

14HS13-1004S-EGS20

SIGNATURE		DATE
DRN	LJ	4.15.2025
APVD	MYX	4.15.2025