

CUSTOMER'S MODEL: NO MODEL  
 END COVER COLOR: BLACK

REV.	REVISION RECORD	BY	DATE
0	ORIGIN	LJ	7.29.2025

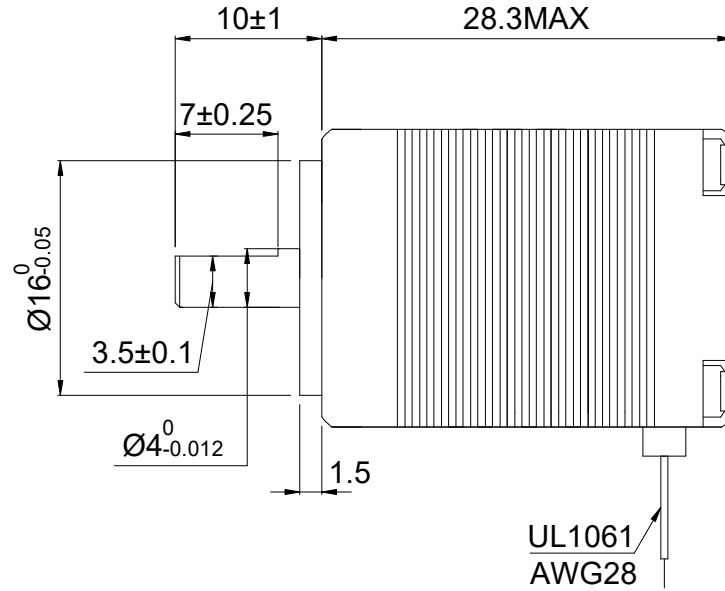

**STEPPER MOTOR**  
 8HS12-0506S  
 S/N: XXXXXXXXXXXXX

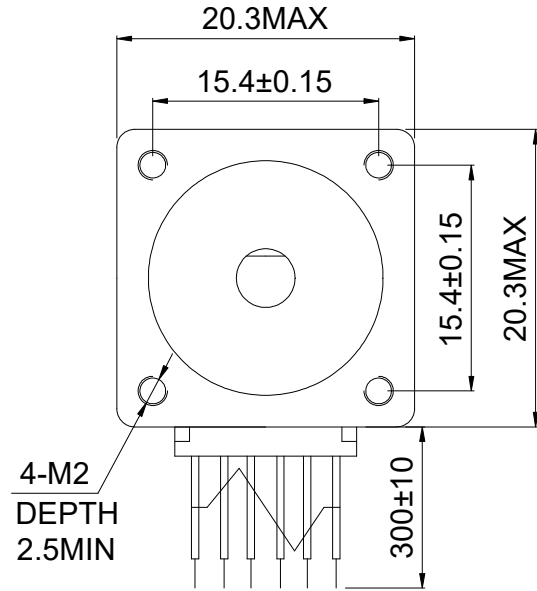

MOTOR CONNECTION			
PIN NO	BIPOLAR	LEADS	WINDING
1	A+	BLK	
2	A-	GRN	
3	B+	RED	
4	B-	BLU	
5	O+	YEL	
6	O-	WHT	

CONNECTION	BIPOLAR
SPECIFICATION	
AMPS/PHASE	0.50
RESISTANCE/PHASE(Ohms)@25°C	11.50±10%
INDUCTANCE/PHASE(mH)@1KHz	1.70±20%
HOLDING TORQUE(Nm)[lb-in]	0.012[0.11]
STEP ANGLE(°)	1.80
STEP ACCURACY(NON-ACCUM)	±5.00%
ROTOR INERTIA(g-cm²)	2.50
WEIGHT(Kg)[lb]	—
AMBIENT TEMPERATURE	-10°C~50°C[14°F~122°F]
INSULATION CLASS	B 130°C[266°F]
TEMPERATURE RISE	MAX.80°C

COMMENT:  
 1.TMBF 6000h OR MORE @ 24V/300RPM  
 2.INSULATION RESISTANCE (NORMAL TEMPERATURE AND HUMIDITY): 100 Mohm  
 3.DIELECTRIC STRENGTH 500VAC FOR 1MIN.(BETWEEN THE MOTOR COILS AND THE MOTOR CASE )

FULL STEP 2 PHASE-Ex.,WHEN FACING MOUNTING END (X)					CCW	CW	THIRD ANGLE PROJECTION
STEP	A+	B+	A-	B-			
1	+	+	-	-			
2	-	+	+	-			
3	-	-	+	+			
4	+	-	-	+			

DIMENSIONS ARE IN MILLIMETERS.  
 TOLERANCES AS BELOW:  
 DECIMALS ANGLES  
 X ±0.5 ±2°  
 X.X ±0.25  
 X.XX ±0.13

**STEPPERONLINE®**

**STEPPER MOTOR**

**8HS12-0506S**

THIS DOCUMENT SHALL NOT BE REPRODUCED NOR SHALL THE INFORMATION CONTAINED HEREIN BE USED BY OR DISCLOSED TO OTHERS UNLESS EXPRESSLY AUTHORIZED IN BY WRITING STEPPERONLINE.

SIGNATURE		DATE
DRN	LJ	7.29.2025
APVD	LDJ	7.29.2025

REV.	0	SCALE	1:1	DWG NO.	A1722
------	---	-------	-----	---------	-------