

CUSTOMER'S MODEL: NO MODEL  
 END COVER COLOR: BLACK

REV.	REVISION RECORD	BY	DATE
0	ORIGIN	LDJ	7.31.2025

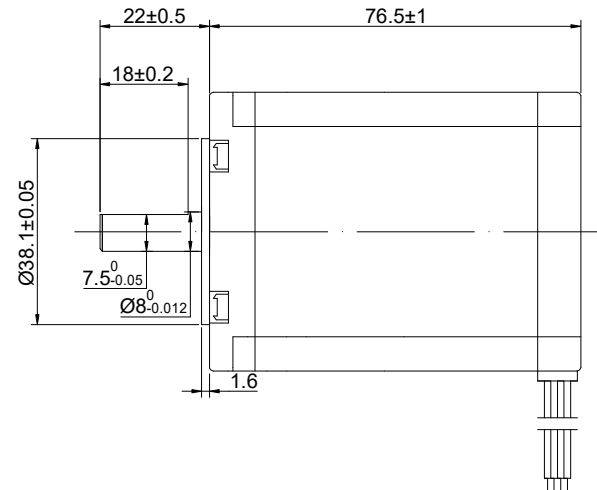
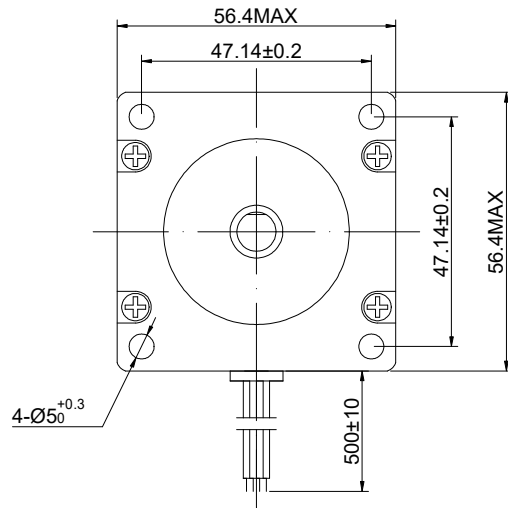

MOTOR CONNECTION			
PIN NO	BIPOLAR	LEADS	WINDING
1	A+	BLK	
4	A-	GRN	
3	B+	RED	
2	B-	BLU	

CONNECTION	BIPOLAR
SPECIFICATION	
AMPS/PHASE	2.80
RESISTANCE/PHASE(Ohms)@25°C	1.13±10%
INDUCTANCE/PHASE(mH)@1KHz	4.80±20%
HOLDING TORQUE(Nm)[lb-in]	1.90[16.82]
STEP ANGLE(°)	1.80
STEP ACCURACY(NON-ACCUM)	±5.00%
ROTOR INERTIA(g-cm²)	440.00
WEIGHT(Kg)[lb]	—
AMBIENT TEMPERATURE	-10°C~50°C[14°F~122°F]
INSULATION CLASS	B 130°C[266°F]
TEMPERATURE RISE	MAX.85°C

**COMMENT:**

- 1.TMBF 6000h OR MORE @ 24V/300RPM
- 2.INSULATION RESISTANCE (NORMAL TEMPERATURE AND HUMIDITY): 100 Mohm
- 3.DIELECTRIC STRENGTH 500VAC FOR 1MIN.(BETWEEN THE MOTOR COILS AND THE MOTOR CASE )

STEP	A+	B+	A-	B-
1	+	+	-	-
2	-	+	+	-
3	-	-	+	+
4	+	-	-	+

FULL STEP 2 PHASE-Ex.,WHEN FACING MOUNTING END (X)  
 DIMENSIONS ARE IN MILLIMETERS.  
 TOLERANCES AS BELOW:  
 DECIMALS ANGLES  
 X ±0.5 ±2°  
 X.X ±0.25  
 X.XX ±0.13  
 THIRD ANGLE PROJECTION

**STEPPERONLINE®**

**STEPPER MOTOR**

**23HS30-2804S2**

THIS DOCUMENT SHALL NOT BE REPRODUCED NOR SHALL THE INFORMATION CONTAINED HEREIN BE USED BY OR DISCLOSED TO OTHERS UNLESS EXPRESSLY AUTHORIZED IN BY WRITING STEPPERONLINE.

SIGNATURE		DATE
DRN	LDJ	7.31.2025
APVD	MYX	7.31.2025

REV.	0	SCALE	2:3	DWG NO.	A4045
------	---	-------	-----	---------	-------