

REV.	REVISION RECORD	BY	DATE
0	ORIGIN	ZPJ	7.17.2025

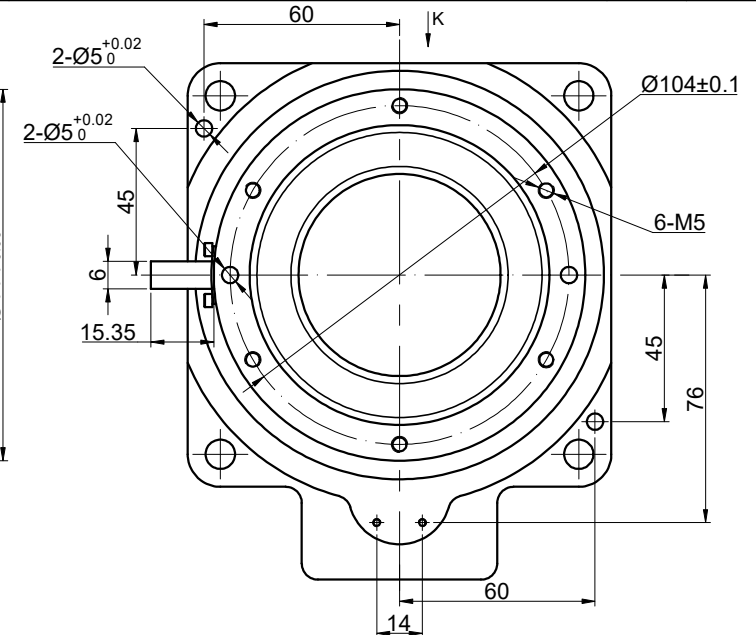

SPECIFICATION	CONNECTION	VALUE
GEAR RATIO		18
EFFICIENCY		95%
POSITION ACCURACY		3arcmin
REPEAT POSITION ACCURACY		±15arcsec
PERMISSIBLE TORQUE(Nm)[lb-in]		20.00[177.01]
ALLOWABLE MOMENT OF INERTIA(Nm)		32.00
MOMENT OF INERTIA(g·cm ²)		81556
MAX. AXIAL LOAD(N)		2000
RECOMMENDED AXIAL LOAD(N)		250
PERMISSIBLE OUTPUT SPEED(RPM)		200
PLATFORM PARALLELISM(MM)		<=0.010
PLATFORM SURFACE JUMPING(MM)		<=0.010
NOISE(dB)		<=65
WATERPROOF RATING		IP40
LIFE(h)		20000
LUBRICATION METHOD		LUBRICATING GREASE

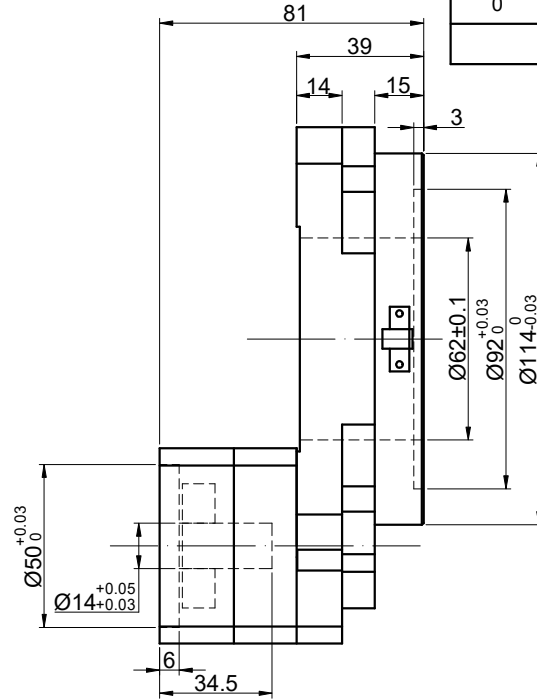
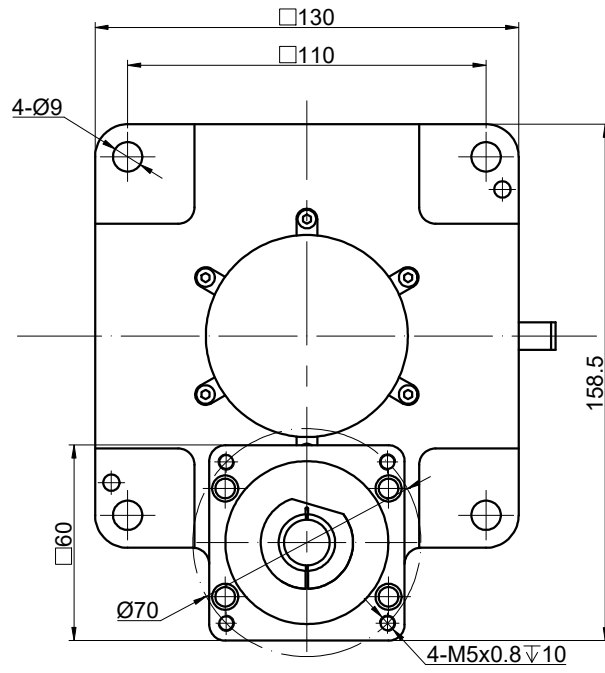
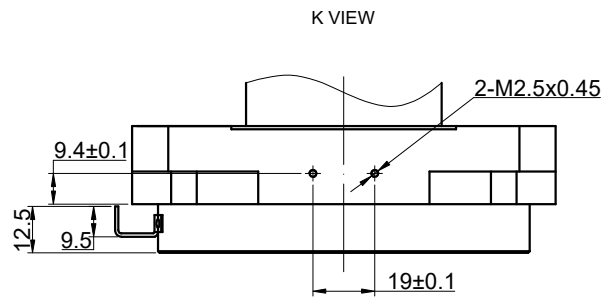

DIMENSIONS ARE IN MILLIMETERS.
TOLERANCES AS BELOW:
DECIMALS ANGLES
X ±0.5 ±2°
X.X ±0.25
X.XX ±0.13

THIRD ANGLE PROJECTION	
SIGNATURE	DATE
DRN ZPJ	7.17.2025
APVD MYX	7.17.2025

STEPPERONLINE®

HOLLOW ROTATING PLATFORM

HRP130KK-G18-D14

REV.	0	SCALE	2:3	DWG NO.	A3903
------	---	-------	-----	---------	-------