

REV.	REVISION RECORD	BY	DATE
0	ORIGIN	ZPJ	7.17.2025

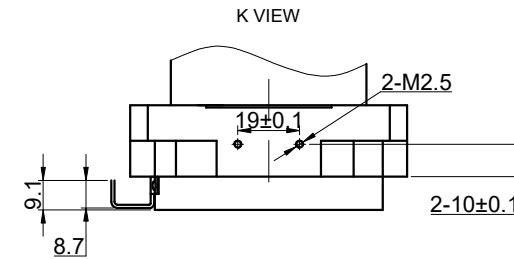
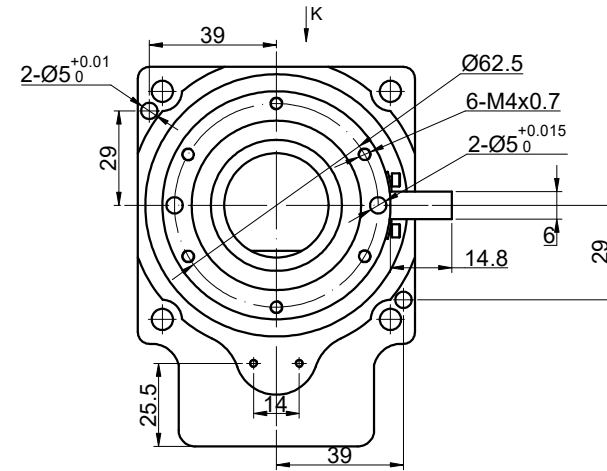
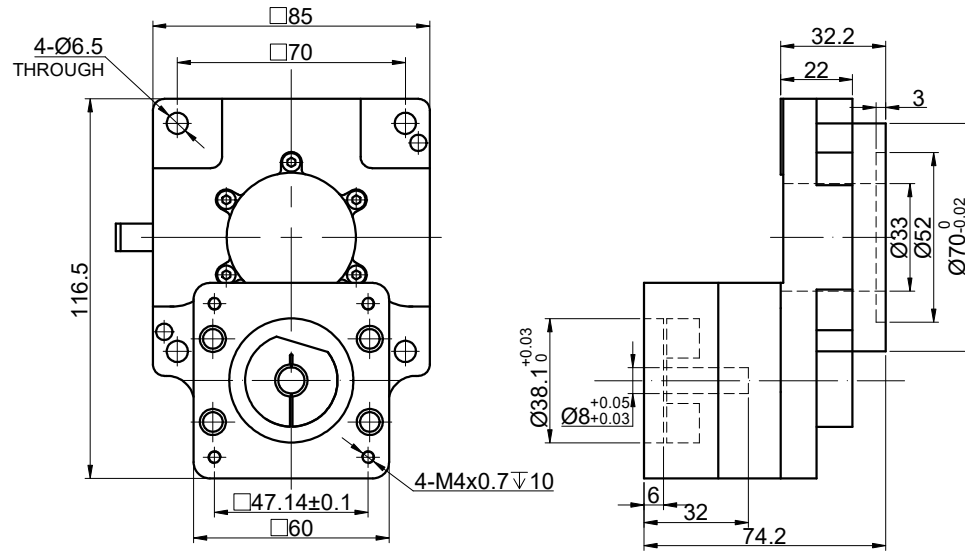

SPECIFICATION	CONNECTION	VALUE
GEAR RATIO		10
EFFICIENCY		95%
POSITION ACCURACY		3arcmin
REPEAT POSITION ACCURACY		±15arcsec
PERMISSIBLE TORQUE(Nm)[lb-in]		10.00[88.51]
ALLOWABLE MOMENT OF INERTIA(Nm)		8.00
MOMENT OF INERTIA(g·cm ²)		12593
MAX. AXIAL LOAD(N)		500
RECOMMENDED AXIAL LOAD(N)		120
PERMISSIBLE OUTPUT SPEED(RPM)		300
PLATFORM PARALLELISM(MM)		<=0.010
PLATFORM SURFACE JUMPING(MM)		<=0.010
NOISE(dB)		<=65
WATERPROOF RATING		IP40
LIFE(h)		20000
LUBRICATION METHOD		LUBRICATING GREASE

DIMENSIONS ARE IN MILLIMETERS.
 TOLERANCES AS BELOW:
 DECIMALS ANGLES
 X ±0.5 ±2°
 X.X ±0.25
 X.XX ±0.13

THIRD ANGLE PROJECTION		
SIGNATURE		DATE
DRN	ZPJ	7.17.2025
APVD	MYX	7.17.2025

STEPPERONLINE®

HOLLOW ROTATING PLATFORM

HRP85KH-G10-D8

REV.	0	SCALE	2:3	DWG NO.	A3897
------	---	-------	-----	---------	-------