

REV.	REVISION RECORD	BY	DATE
0	ORIGIN	ZPJ	7.17.2025

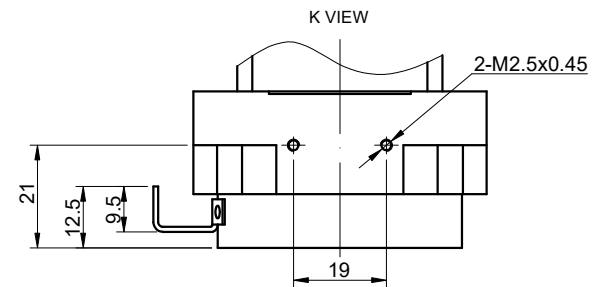
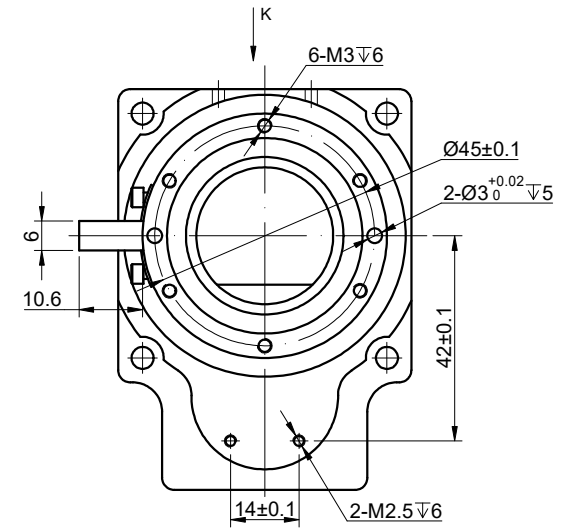
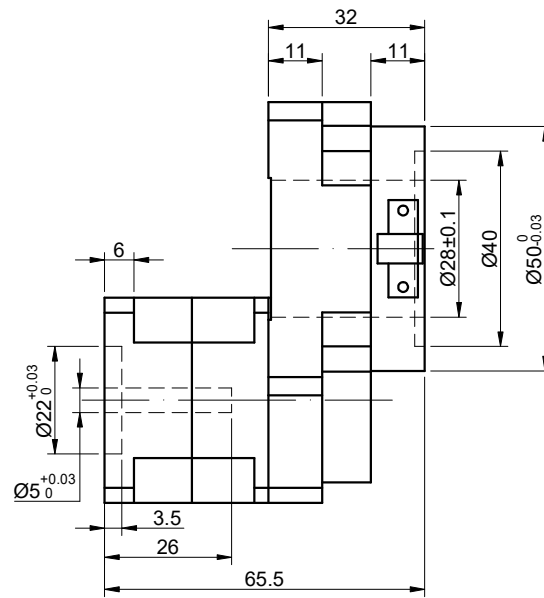
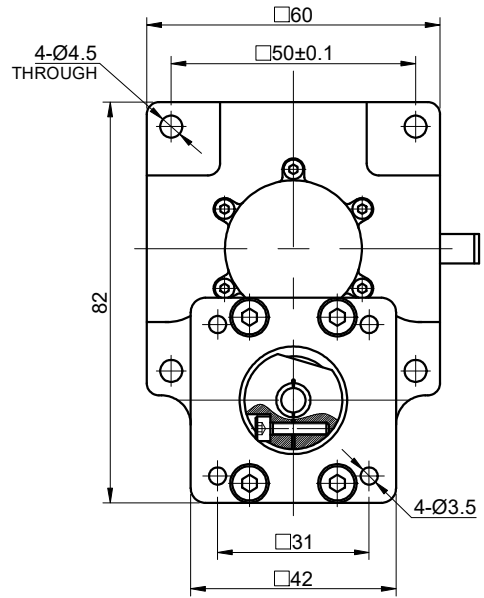

SPECIFICATION	CONNECTION	VALUE
GEAR RATIO		5
EFFICIENCY		95%
POSITION ACCURACY		3arcmin
REPEAT POSITION ACCURACY		±15arcsec
PERMISSIBLE TORQUE(Nm)[lb-in]		5.20[46.02]
ALLOWABLE MOMENT OF INERTIA(Nm)		5.60
MOMENT OF INERTIA(g·cm ²)		3500
MAX. AXIAL LOAD(N)		280
RECOMMENDED AXIAL LOAD(N)		50
PERMISSIBLE OUTPUT SPEED(RPM)		200
PLATFORM PARALLELISM(MM)		<=0.010
PLATFORM SURFACE JUMPING(MM)		<=0.010
NOISE(dB)		<=65
WATERPROOF RATING		IP40
LIFE(h)		20000
LUBRICATION METHOD		LUBRICATING GREASE

DIMENSIONS ARE IN MILLIMETERS.
TOLERANCES AS BELOW:
DECIMALS ANGLES
X ±0.5 ±2°
X.X ±0.25
X.XX ±0.13

THIRD ANGLE PROJECTION		
SIGNATURE		DATE
DRN	ZPJ	7.17.2025
APVD	MYX	7.17.2025

STEPPERONLINE®

HOLLOW ROTATING PLATFORM

HRP60KE-G5-D5

REV.	0	SCALE	1:1	DWG NO.	A3894
------	---	-------	-----	---------	-------