

CUSTOMER'S MODEL: NO MODEL
 END COVER COLOR: BLACK

REV.	REVISION RECORD	BY	DATE
0	ORIGIN	ZPJ	2.4.2026

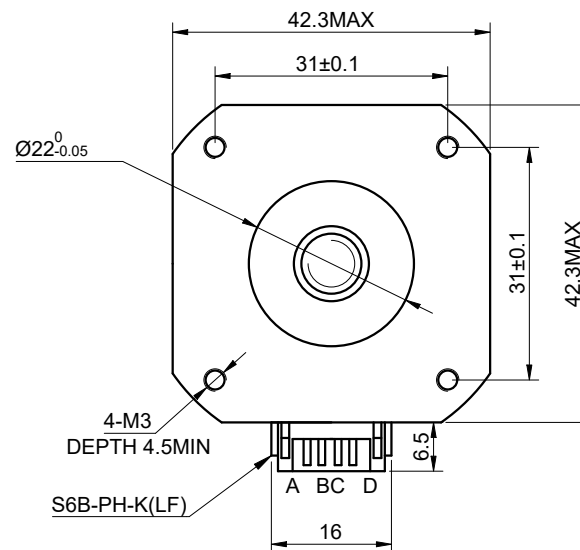
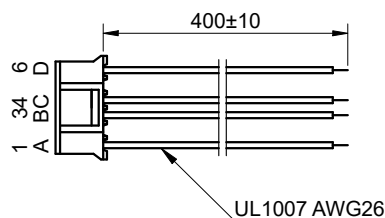
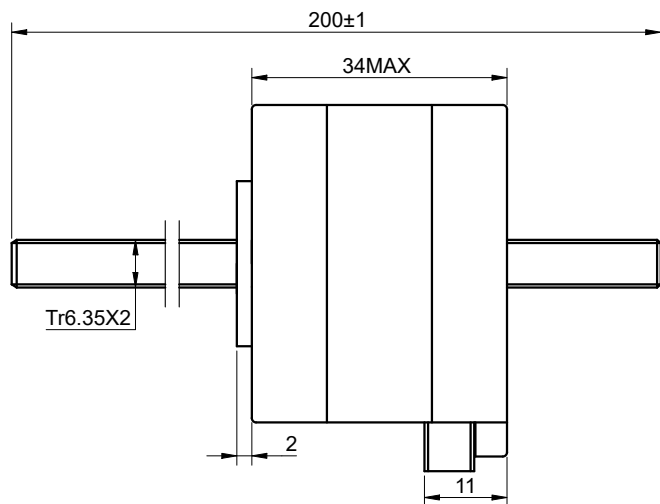

SPECIFICATION	CONNECTION	BIPOLAR
AMPS/PHASE		0.84
RESISTANCE/PHASE(Ohms)@25°C		5.75±10%
INDUCTANCE/PHASE(mH)@1KHz		9.3±20%
HOLDING TORQUE(Nm)[lb-in]		0.28[2.48]
STEP ANGLE(°)		1.80
STEP ACCURACY(NON-ACCUM)		±5.00%
LEAD(mm)		2
LINEAR TRAVEL/STEP(mm)		0.01
AMBIENT TEMPERATURE		-10°C~50°C[14°F~122°F]
INSULATION CLASS		B 130°C[266°F]
TEMPERATURE RISE		MAX.80°C
AMBIENT HUMIDITY		MAX.85%

COMMENT:
 1.TMBF 6000h OR MORE @ 24V/300RPM
 2.INSULATION RESISTANCE (NORMAL TEMPERATURE AND HUMIDITY): 100 Mohm
 3.DIELECTRIC STRENGTH 500VAC FOR 1MIN.(BETWEEN THE MOTOR COILS AND THE MOTOR CASE)

MOTOR CONNECTION			
PIN NO	BIPOLAR	LEADS	WINDING
1	A+	RED	
4	A-	GRY	
3	B+	YEL	
6	B-	GRN	

FULL STEP 2 PHASE-Ex.,WHEN FACING MOUNTING END (X)						DIMENSIONS ARE IN MILLIMETERS.	
STEP	A+	B+	A-	B-	CCW	CW	TOLERANCES AS BELOW:
							DECIMALS
1	+	+	-	-			X ±0.5
2	-	+	+	-			X.X ±0.25
3	-	-	+	+			X.XX ±0.13
4	+	-	-	+			

STEPPERONLINE®

STEPPER MOTOR

17N13S0844AF4-200RS

THIS DOCUMENT SHALL NOT BE REPRODUCED NOR SHALL THE INFORMATION CONTAINED HEREIN BE USED BY OR DISCLOSED TO OTHERS UNLESS EXPRESSLY AUTHORIZED IN BY WRITING STEPPERONLINE.

SIGNATURE		DATE
DRN	ZPJ	2.4.2026
APVD	MYX	2.4.2026