

调速减速电机 SPEED CONTROL GEAR MOTOR

200W 104mm

STEPPERONLINE®



电机型号/性能 List of motor characteristics

电机型号 Motor Model	输出功率 Output Power	电压 Voltage	频率 Frequency	电流 Current	转速范围 Speed Range	额定转矩 Rated Torque		启动转矩 Starting Torque	运行电容 Capacitor
齿轮轴型 Pinion Shaft	圆轴型 Round Shaft	W	V	Hz	r/min	90r/min	1200r/min	mN.m	μF/VAC
6IK200RGU-CF	6IK200RA-CF	200	1ph220	50	90~1350	500	1450	1050	10.0/450
				60	90~1550	450	1200	900	
6IK200RGU-AF	6IK200RA-AF	200	1ph110	50	90~1350	500	1450	950	35.0/250
				60	90~1550	450	1200	920	

●从调速电机转矩/转速曲线可知,虽然调速电机的调速范围为:50Hz...90~1350转/分钟;60Hz...90~1550转/分钟。但由于低速时(≤400转/分钟),电机转矩下降较多,易发生过载,且电机直连风扇冷却效果差,易发热,因此必须预留足够的功率余量,并且不要经常工作在低速区。因此电机最佳调速范围为:50Hz...900~1350转/分钟;60Hz...900~1550转/分钟。

●各种安全规格以电机铭牌上的型号名取得认证。

●注:“A”型号中电压为110V时,配置电容器容量以实际铭牌为准。

●It can be seen from the torque/speed curve of the speed-regulating motor, although the speed range of the speed-regulating motor is :50Hz... 90~1350 RPM; 60 Hz... 90~1550 revolutions per minute. But due to the low speed (400 RPM) or less, when the motor torque drop more, prone to overload, and poor motor directly connected the fan cooling effect, easy to heat, so must set aside enough power margin, and don't often work in low speed zone. Therefore, the optimal speed range of the motor is :50Hz... 900~1350 revolutions per minute; 60 Hz... 900~1550 RPM.

●When the motor is approved under various safety standards, the model name on the nameplate is the approved model name.

●Note *sAlt means the voltage 110v. the assembly capacitor vaule it is according the labe.

减速箱减速比/性能对照表 Gear reduction ratio/performance comparison

减速比 Gear Ratio	3	3.6	5	6	7.5	9	10	12.5	15	18	20	25	30	36	40	50	60	75	90	100	120	150	180	200	
50Hz	转速 Speed r/min	450	375	270	225	180	150	135	108	90	75	67.5	54	45	37.5	33.7	27	22.5	18	15	13.5	11	9	7.5	6.75
	转矩 Torque N.m	3.11	3.74	5.19	6.23	7.78	9.34	11.75	14.01	16.81	16.81	21.01	25.21	30.26	33.62	40	40	40	40	40	40	40	40	40	40
60Hz	转速 Speed r/min	516	430	310	258	206	172	155	124	103	86	77.5	62	51.6	43	38.75	31	25.8	20.6	17.2	15.5	12.9	10.3	8.6	7.75
	转矩 Torque N.m	2.58	3.09	4.29	5.15	6.44	7.73	9.72	9.66	11.59	13.91	13.91	17.39	20.86	25.04	27.82	34.77	40	40	40	40	40	40	40	40

●表中转速是以电机的平均转速为基数除以减速比而算出的数值。实际转速将随负载大小而变化,变化范围2~20%。

●表中色框表示输出轴的旋转方向与电机旋转方向相反。

●表中转矩是以电机额定转矩×减速比×传动效率计算而得。

●减速箱的最大容许转矩为40N.M。

●In the table, the speed is calculated from the base of the motor's average speed divided by the deceleration ratio. The actual speed will vary with the load, ranging from 2% to 20%.

- The box in the table indicates that the rotation direction of the output axis is opposite to that of the motor.
- Table transfer torque is calculated from motor rated torque * deceleration ratio * transmission efficiency.
- The maximum allowable torque of the decelerator is 40N.M.

外形尺寸(单位mm) Dimension (unit mm)

●圆轴电机

重量 Weight: 5.1kg

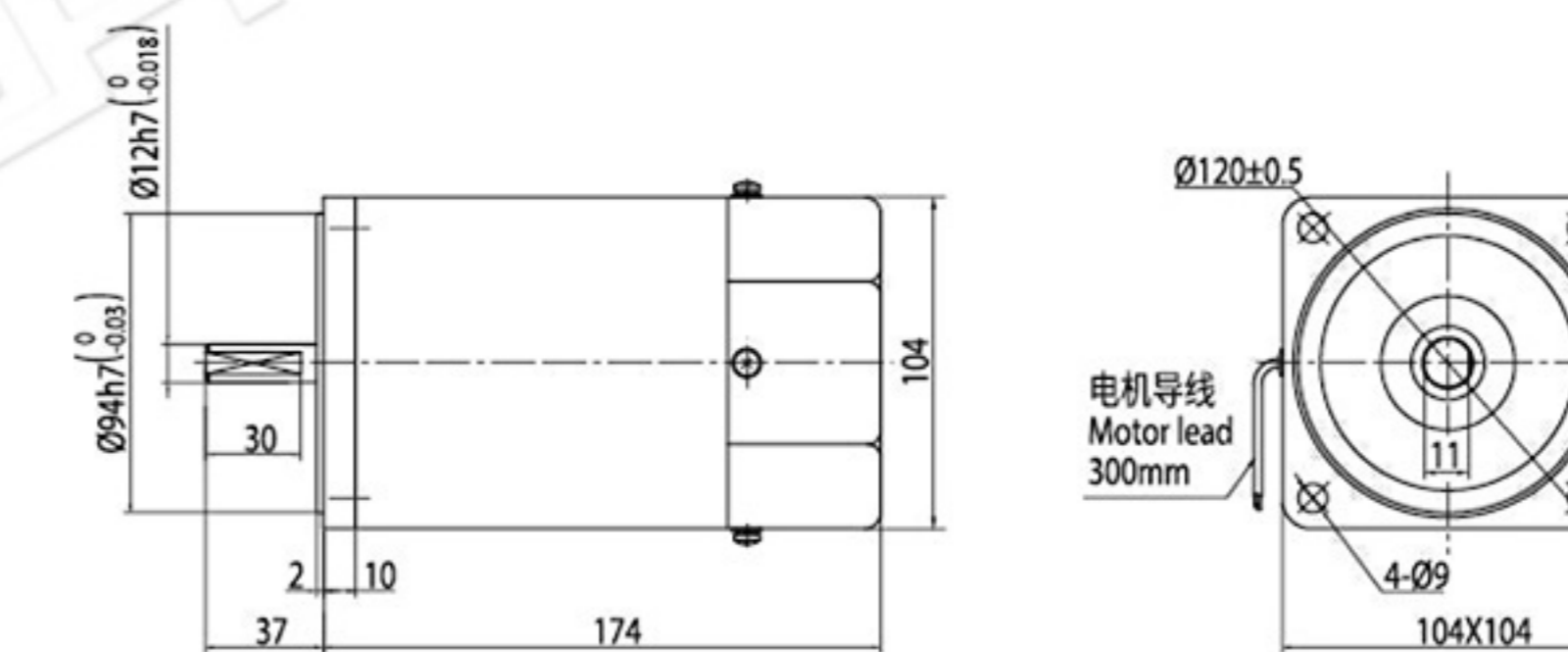

●组合: 引线型电机+标准减速箱(减速比1:3~200)

重量 Weight: 7.2kg

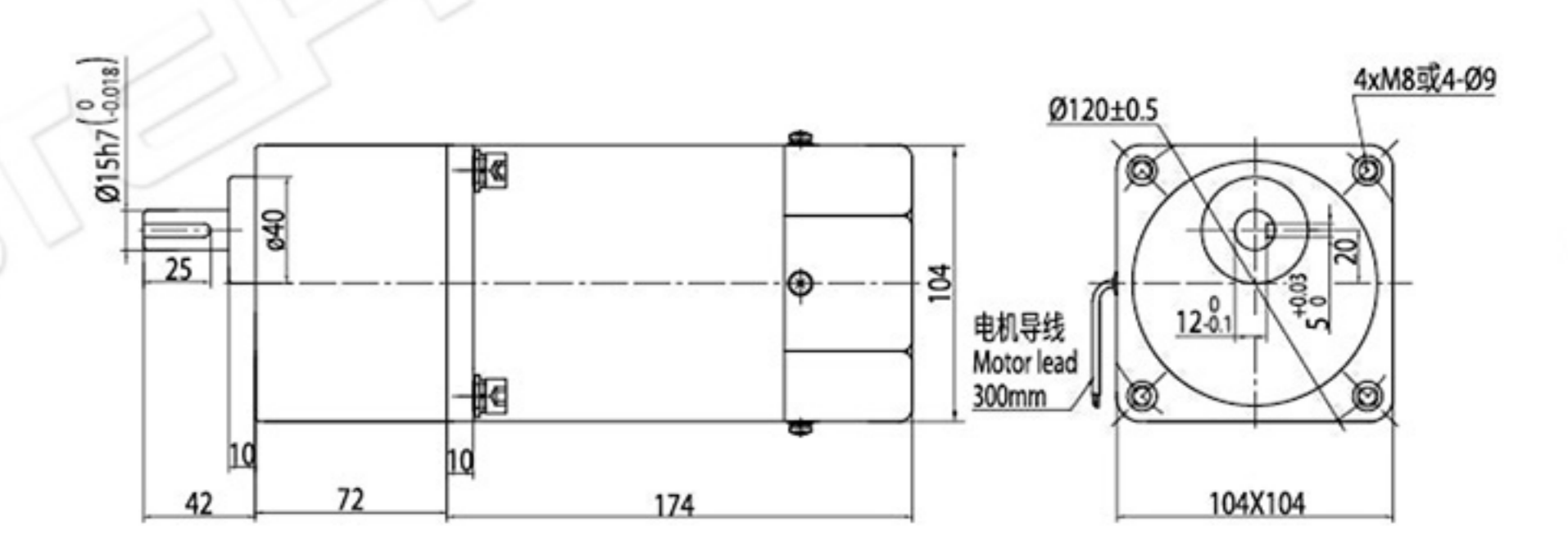

●组合: 接线盒(可选, 详见 P150)型电机+标准减速箱(减速比1:3~200)

重量 Weight: 7.35kg

●键(减速器附件)

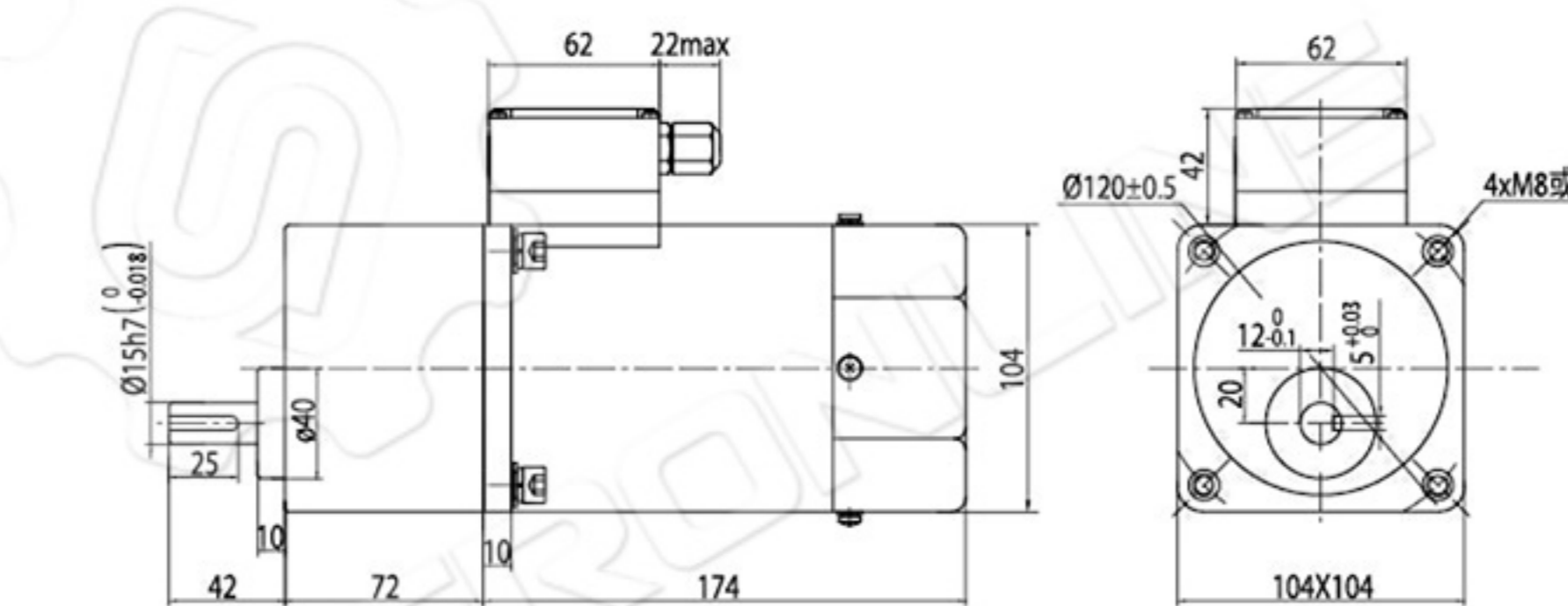

短箱体Short Gear Box

●其中速比3~40 可以做成短型减速箱,高度为65mm。Gear ratio 3~40, short case is possible, Height of 65 mm.

接线图Wiring Diagram

●运转方向指从电机轴看来的方向。CW 表示顺时针方向, CCW 表示逆时针方向。

●表中所记型号为齿轮轴型, 圆轴型亦同。

●The direction of motor rotation is as viewed from the shaft end of motoc CW represents the clockwise direction, while CCW represents the counterclockwise direction.

●Name indicated in the list is pinion shaft we, also valid for the equivalent round shaft type.

