

REV.	REVISION RECORD	BY	DATE
0	ORIGIN	LDJ	1.11.2024

CUSTOMER'S MODEL: NO MODEL  
END COVER COLOR: BLACK

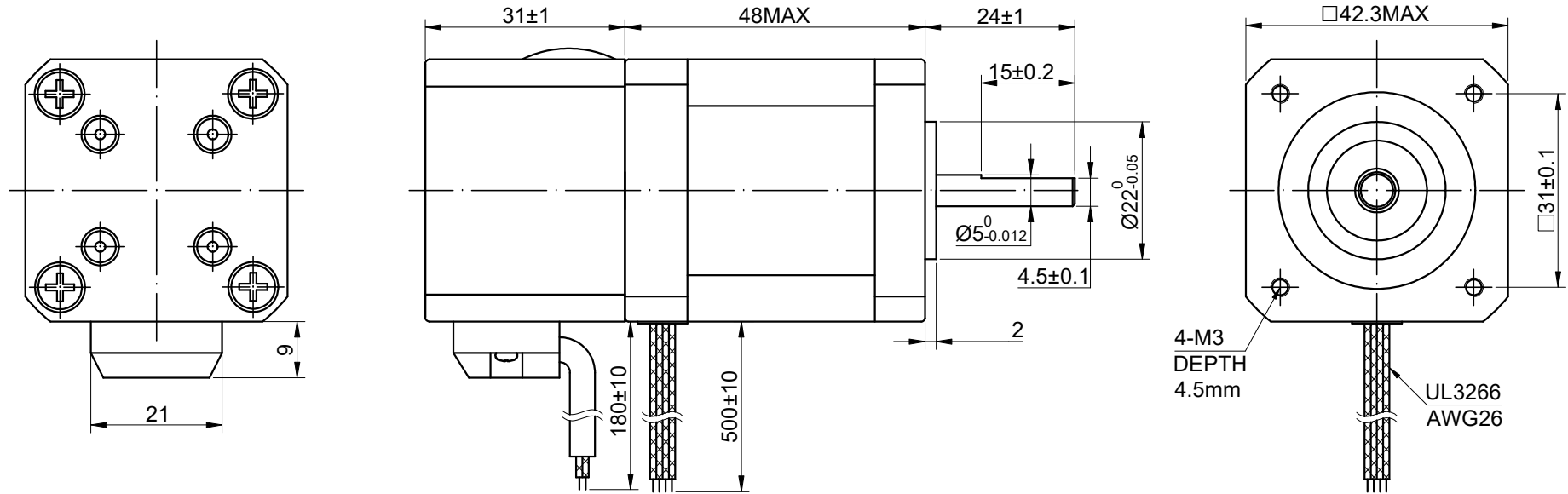

SPECIFICATION	CONNECTION	BIPOLAR
AMPS/PHASE		2.00
RESISTANCE/PHASE(Ohms)@20°C		1.30±10%
INDUCTANCE/PHASE(mH)@1KHz		2.00±20%
HOLDING TORQUE(Nm)[lb-in]		0.52[4.60]
STEP ANGLE(°)		1.80
STEP ACCURACY(NON-ACCUM)		±5.00%
ROTOR INERTIA(g-cm²)		82.00
WEIGHT(Kg)[lb]		0.52[1.15]
AMBIENT TEMPERATURE		0°C~50°C[32°F~122°F]
INSULATION CLASS		B 130°C[266°F]
TEMPERATURE RISE		MAX.80°C

COMMENT:  
 1.DYNAMIC AXIAL LOAD: 10N MAX  
 2.DYNAMIC RADIAL LOAD @ SHAFT LENGTH 20mm: 21N MAX  
 3.TMBF 6000h OR MORE @ 24V/300RPM  
 4.INSULATION RESISTANCE (NORMAL TEMPERATURE AND HUMIDITY): 100 Mohm  
 5.DIELECTRIC STRENGTH 500VAC FOR 1MIN.(BETWEEN THE MOTOR COILS AND THE MOTOR CASE )

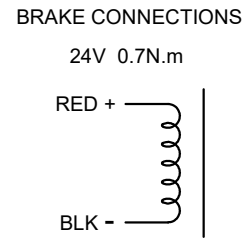

MOTOR CONNECTION			
PIN NO	BIPOLAR	LEADS	WINDING
1	A+	BLK	
2	A-	GRN	
3	B+	RED	
4	B-	BLU	

FULL STEP 2 PHASE-Ex.,WHEN FACING MOUNTING END (X)					DIMENSIONS ARE IN MILLIMETERS. TOLERANCES AS BELOW: DECIMALS ANGLES X ±0.5 ±2° X.X ±0.25 X.XX ±0.13
STEP	A+	B+	A-	B-	
1	+	+	-	-	
2	-	+	+	-	
3	-	-	+	+	
4	+	-	-	+	

THIS DOCUMENT SHALL NOT BE REPRODUCED NOR SHALL THE INFORMATION CONTAINED HEREIN BE USED BY OR DISCLOSED TO OTHERS UNLESS EXPRESSLY AUTHORIZED IN BY WRITING STEPPERONLINE.

SIGNATURE		DATE
DRN	LDJ	1.11.2024
APVD	HW	1.11.2024

**STEPPERONLINE®**

**STEPPER MOTOR**

**17HS19-2004D-B070**

REV.	0	SCALE	1:1	DWG NO.	A2789
------	---	-------	-----	---------	-------